

24

FANTIN

Uno (1973)

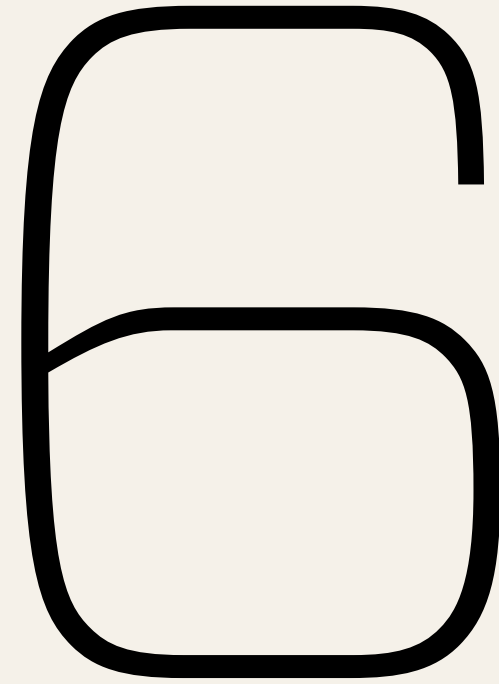

Values
Valores
Valeurs

Long-standing dedication Historia y pasiones Histoire et passions

Fantin was founded in 1968 in Bannia near Fiume Veneto, in the heart of one of the most important industrial areas in Italy and the whole of Europe. The helm of the company has always remained in the hands of the Fantin family. They have shaped it into a specialist manufacturer of metal furniture and solutions that are renowned on the market for one key value: quality, which in this case means a blend of visual appeal, solidity, functionality and sustainability.

Fantin fue fundada en 1968 en Bannia di Fiume Veneto, en el corazón de una de las áreas industriales italianas y europeas más importantes. La familia Fantin, siempre al frente de la empresa, ha creado una compañía especializada en la producción de muebles y soluciones metálicas, reconocida por el mercado gracias a un valor esencial: la calidad como síntesis de belleza y solidez, funcionalidad y sostenibilidad.

Fantin a été fondée en 1968 à Bannia di Fiume Veneto, au cœur de l'une des plus importantes zones industrielles italiennes et européennes. La famille Fantin, depuis toujours à la tête de l'entreprise, a créé une firme spécialisée dans la production de meubles et de solutions en métal, réputée sur le marché pour une valeur essentielle : la qualité, à savoir une synthèse de beauté et de solidité, de fonctionnalité et de durabilité.

Metal and ingenuity Metal e ingenio Métal et ingéniosité

We have vast experience of working with metal, which we have been doing devotedly for over 50 years. The collections that we conceive and produce stem from tireless research and ongoing development of design skills and solutions. They are enhanced by mechanical manufacturing processes and we always strive to strike a balance between industrial approaches and craftsmanship, efficient production and attention to detail.

El metal es el material con el que hemos trabajado con pasión desde hace más de 50 años y del cual hemos adquirido nuestra experiencia. Diseñamos y producimos nuestras colecciones gracias a la investigación continua y al desarrollo de soluciones y habilidades de diseño, mejoradas por la calidad del proceso mecánico, en un equilibrio entre industria y artesanía, eficiencia de producción y atención al detalle.

Nous avons une grande expérience du travail du métal, que nous pratiquons avec passion depuis plus de 50 ans. Les collections que nous concevons et produisons sont le fruit d'une recherche incessante et d'un développement continu des compétences et des solutions en matière de design. Celles-ci sont renforcées par la qualité de nos processus de fabrication mécanique, dans un équilibre parfait entre industrie et artisanat, efficacité de la production et souci du détail.

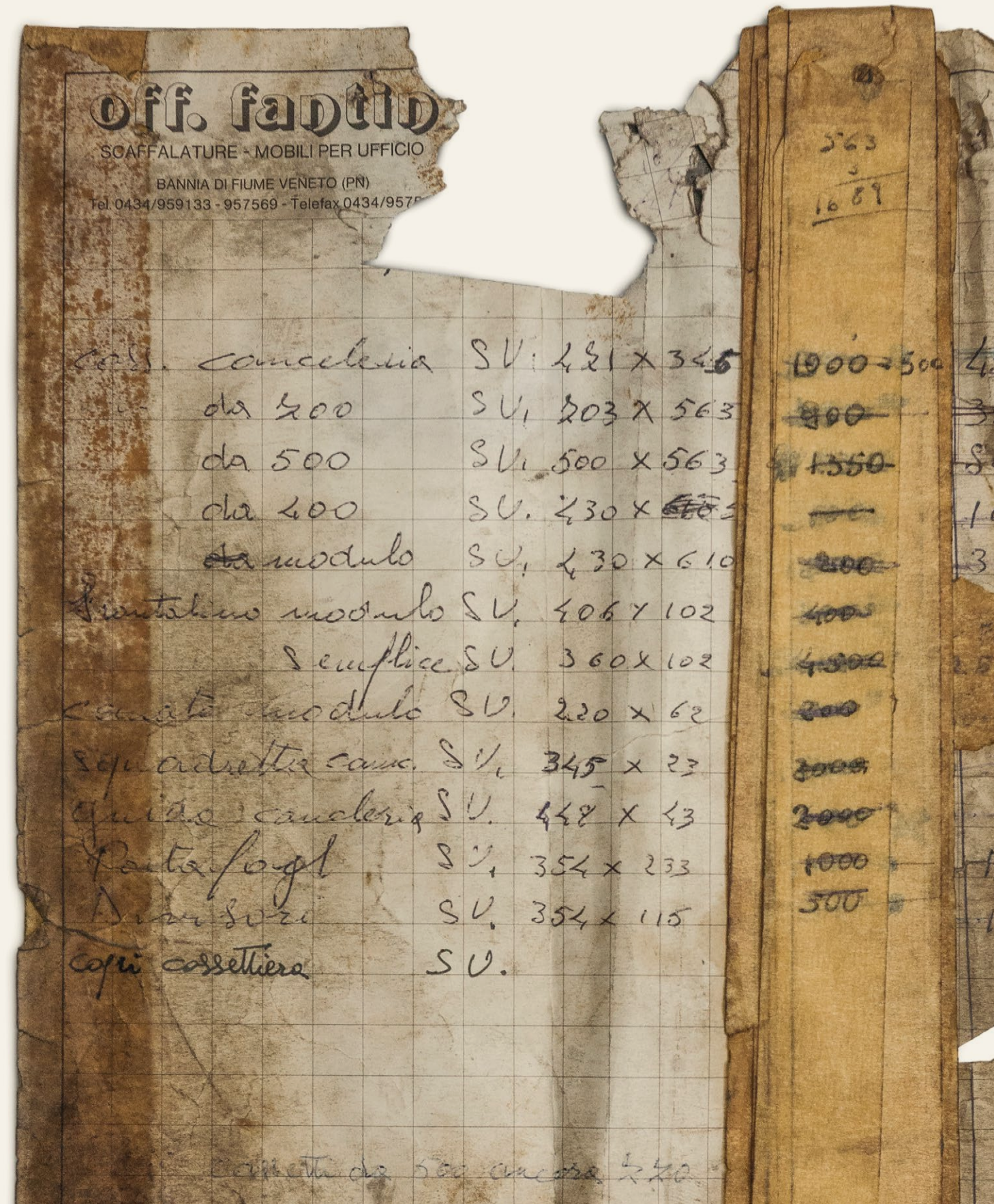

Versatile looks Estética versátil Esthétique polyvalente

The clean-cut designs intelligently combine versatility and visual appeal. The attractive, practical items of furniture are the perfect match for every setting: from homes to offices, from shops to factories. Our goal is to help to create environments where people feel comfortable, by catering to their needs and reflecting their personalities.

El diseño esencial combina estética y versatilidad de forma inteligente. Muebles bellos, funcionales y perfectos en cualquier contexto, desde la casa hasta la oficina, desde la tienda hasta la industria. Nuestro objetivo es contribuir a crear ambientes donde las personas puedan sentirse cómodas, interpretando las necesidades y la personalidad de quienes viven allí.

Le design épuré allie intelligemment l'esthétique et la polyvalence. Des meubles beaux, fonctionnels et parfaits dans tous les contextes : de la maison au bureau, du magasin à l'industrie. Notre objectif est de contribuer à créer des environnements où les personnes se sentent à l'aise, en interprétant leurs besoins et leur personnalité.

Balanced colours Equilibrio cromático Équilibre chromatique

For all of our collections, we have a breathtaking colour palette consisting of more than 60 different finishes. Ranging from neutral tones to the brightest hues, they provide the scope for numerous aesthetic solutions. Through surfaces, we endeavour to breathe life into metal and bring to fruition the creative hopes and dreams of even our most imaginative and visionary customers.

Con todas nuestras colecciones ofrecemos una paleta de colores sorprendente, compuesta por más de 60 acabados que van desde los colores neutros hasta los más intensos, ofreciendo múltiples soluciones estéticas. Nuestro objetivo es darle vida al metal a través de la superficie, para satisfacer la creatividad y los sueños de nuestros clientes, incluso los más curiosos y visionarios.

Pour toutes nos collections, nous proposons une palette de couleurs surprenante, composée de plus de 60 finitions différentes. Allant des tons neutres aux teintes les plus vives, elles permettent de multiples solutions esthétiques. Par le biais des surfaces, nous nous efforçons de donner une âme au métal et de réaliser les rêves et les aspirations créatives de nos clients, même les plus curieux et les plus visionnaires.



Flexible production Producción flexible Production flexible

The entire production cycle takes place in our facilities: from the arrival of the raw materials to mechanical cutting, punching, bending, tack welding, final welding, powder coating, assembly and packaging for delivery. This enables us to be flexible and satisfy individual product needs while also carrying out more complex activities for the contract market.

Todo el ciclo productivo se desarrolla dentro de nuestra fábrica. Desde la llegada de la materia prima hasta el procesamiento mecánico de corte, punzonado, plegado, punteado y soldadura, hasta el pintado en polvo, el montaje y embalaje para el envío. Esto permite una gestión flexible que satisface tanto la solicitud de cada producto como las actividades más complejas relacionadas con todo el proyecto de amueblamiento de los espacios.

Tout le cycle de production se déroule dans notre usine : de l'arrivée des matières premières aux usinages mécaniques de la découpe, du poinçonnage, du pliage, du pointage et du soudage, jusqu'au thermolaquage, au montage et à l'emballage pour la livraison. Cela nous permet d'être flexibles et de satisfaire les besoins liés à un produit donné comme à ceux des activités professionnelles les plus complexes.

Sustainable outlook Filosofía sostenible Philosophie durable

With the close ties between human well-being and the environment in mind, we have a sustainable outlook that takes concrete form in all of our collections. Our products are made of 100% recyclable metal, all of our powder coatings are non-toxic and we have short supply chains (all suppliers are based within 25 km of our premises). In addition, our solid, durable products help to reduce waste in terms of resources, raw materials and energy, thus lowering their environmental impact.

Promovemos una filosofía sostenible porque reconocemos el estrecho vínculo entre el bienestar humano y el medio ambiente. Esta filosofía se refleja en todas nuestras colecciones con productos fabricados en metal 100% reciclable, pinturas en polvo exclusivas y no tóxicas, cadena de suministro corta con proveedores que están a menos de 25 km de nuestra sede; productos sólidos y duraderos, lo cual garantiza un menor uso de recursos, materias primas y energía y, en consecuencia, un menor impacto ambiental.

Reconnaissant le lien étroit entre le bien-être humain et l'environnement, nous promovons une philosophie durable, qui s'incarne dans toutes nos collections : produits en métal 100 % recyclable ; revêtements en poudre strictement non toxiques; chaîne d'approvisionnement courte (à moins de 25 km de notre siège) ; solidité et longévité des produits, qui garantissent une utilisation moindre des ressources, des matières premières et de l'énergie et, par conséquent, un plus faible impact sur l'environnement.



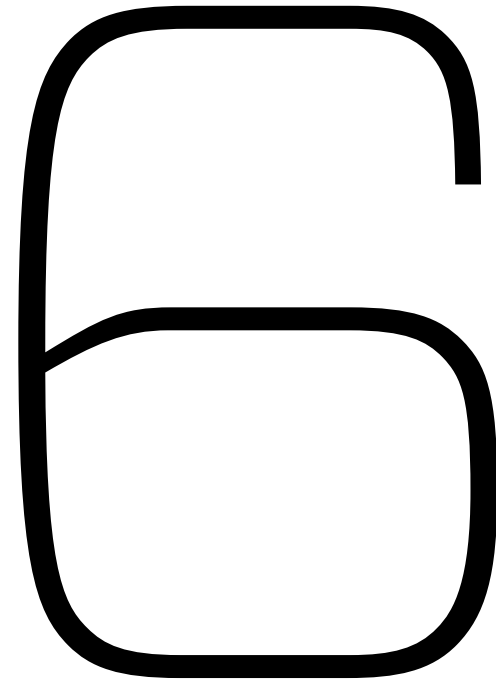
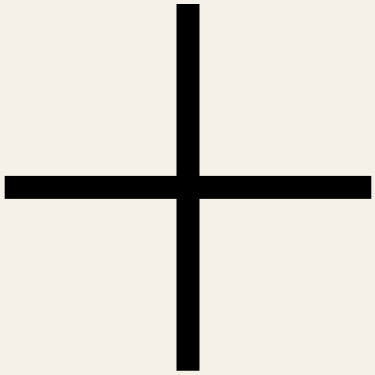

Environments
Contextos
Contextes

home



work



retail



community



outdoor



scenography



67.24

Pink clay / Arcilla rosa / Argile rose

Embossed / Gofrado / Gaufré

FANTIN 2024

Frame

Bookcase system 16

- **Kitchens & workbenches** 32

Tall units 52

- **Stools** 60

Sideboards & cupboards 66

Beds 78

Tables & desks 90

Hug

- **Tables & stools** 98

Hangers 110

Wave

Desks & add-ons 114

- **Still** 120

Uno 130

Uno living 142

Ali 146

Just 154

Cambio 162

- **Run** 174

Mya 178

- **Classic** 182

Essenza 188

Binaria 194

Vela 202

Discovery 210

Ad hoc 220

Indoor finishes 232

Outdoor finishes 240

- Some models are suitable for outdoor use.
Algunos modelos están disponibles para exteriores.
Certains modèles sont disponibles pour une utilisation en extérieur.

Frame

Bookcase system

Salvatore Indriolo, 2019



The distinguishing characteristics of the Frame bookcase selection are rational right-angled lines and endless composition possibilities: three lengths of shelves with six different heights can be freely combined with backboards, sides and compartments with top and bottom opening doors, all of which are inset in the frame. The system has been designed with no visible holes or screws, thus shining the spotlight on the clean-cut appearance of every detail.

El sistema de bibliotecas Frame se caracteriza por la racionalidad de las líneas ortogonales y las infinitas posibilidades de composición. Tres estantes con seis longitudes en los que se pueden colocar libremente fondos, laterales y vanos con puertas rebatibles y batientes, todos insertados en el marco. Además, el sistema ha sido diseñado sin orificios visibles ni tornillos de unión, para permitir la limpieza formal de cada detalle.

Le système de bibliothèques Frame se distingue par la rationalité de ses lignes orthogonales et par ses possibilités de composition infinies : trois longueurs d'étagères réparties sur six niveaux, sur lesquelles agencer librement dos, panneaux latéraux et rangements avec portes rabattables et relevables, tous encastrés à fleur du cadre. Le système a également été conçu sans trous ni vis apparentes, afin de mettre en valeur la pureté formelle des moindres détails.

Uprights / Montantes / Montants

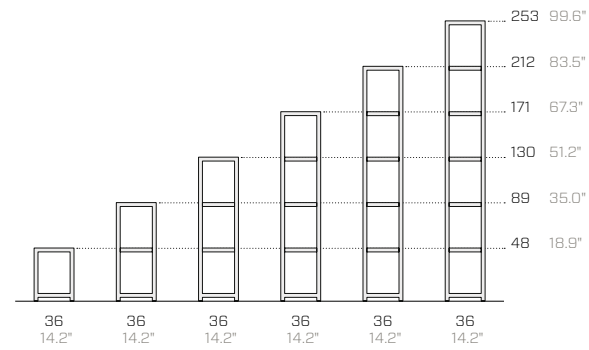

Shelves / Estantes / Étagères



The Frame bookcase selection is suitable for use in offices in all of its possible forms. It was designed with no visible holes or screws, thus shining the spotlight on the clean-cut appearance of every detail.

El sistema de bibliotecas Frame, apto para contextos de oficina con todas sus opciones de composición, ha sido diseñado sin orificios visibles ni tornillos de unión, para permitir la limpieza formal de cada detalle.

Le système de bibliothèques Frame, adapté à une utilisation dans les bureaux grâce à toutes ses possibilités de composition, a été conçu sans trous ni vis apparentes, afin de mettre en valeur la pureté formelle des moindres détails.



Back panels / Fondos / Dos

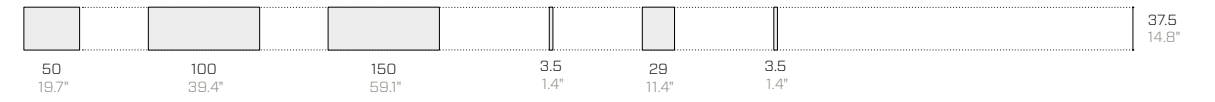

Sides / Laterales / Panneaux latéraux

Vertical opening doors / Puertas rebatibles / Portes relevables

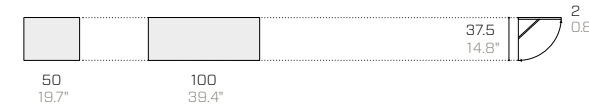

Tilt & turn doors / Puertas batientes / Portes rabattables

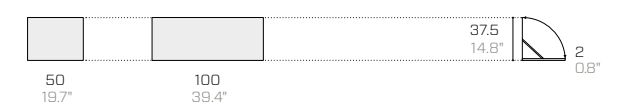











Frame

Kitchens & workbenches

Salvatore Indriolo, 2018



archiproducts
AWARDS
WINNER

archiproducts
AWARDS
WINNER
SUSTAINABILITY



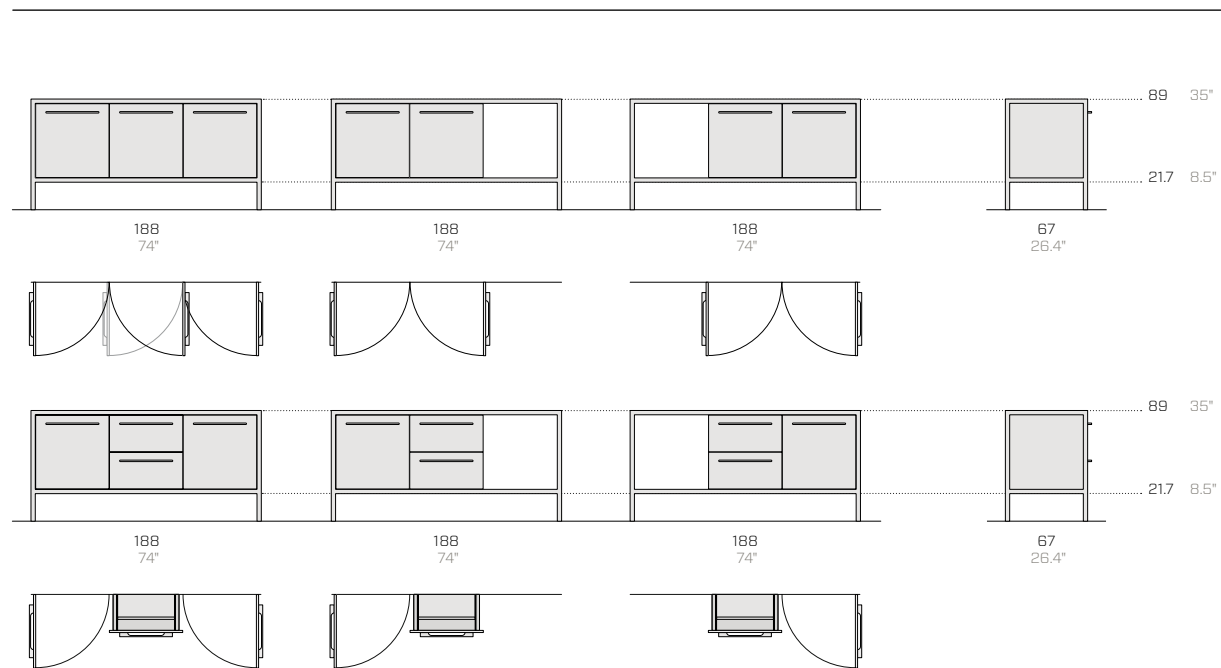

Frame kitchens are offered in 2 or 3 modules, with 4 mm steel tops – available in Vintage and satin finishes – or in tone-on-tone acid-etched glass with all Fantin finishes. Rounding off the options are open compartments and wall panelling in versions with and without a shelf with built-in lighting, which optimize space while adding plenty of personality.

Las cocinas Frame se ofrecen en 2 o 3 módulos, con encimeras de acero de 4 mm – en acabados Vintage y satinado – o en cristal satinado a tono con todos los acabados Fantin. La oferta se completa con los compartimentos abiertos y los paneles de pared, en las versiones con o sin estante con iluminación integrada, para optimizar el espacio con personalidad.

Les cuisines Frame sont proposées en 2 ou 3 modules, avec des plans de travail en acier de 4 mm – disponibles dans les finitions Vintage et satinée – ou en verre dépoli ton sur ton avec toutes les finitions Fantin. Des niches ouvertes et des panneaux muraux viennent compléter l'offre, dans les variantes avec ou sans étagère avec éclairage intégré, optimisant l'espace avec une touche de personnalité.











Structure: 18.21 Dusty blue + Acid-etched glass top: G18.23 Dusty blue



Structure: 19.18 Gentian blue + Acid-etched glass top: G19.23 Gentian blue



Structure: 20.19 Steel blue + Acid-etched glass top: G20.23 Steel blue



Frame Kitchen is also available in outdoor versions, thanks to a cataphoresis treatment that guarantees high resistance to weather conditions.

Frame Kitchen también está disponible en versiones para exteriores, gracias a un tratamiento de cataforesis que garantiza una alta resistencia a los agentes atmosféricos.

Frame Kitchen est également disponible en version pour l'extérieur, grâce à un traitement de cataphorèse qui garantit une grande résistance aux agents atmosphériques.





Frame workbenches come with three top options: Barazza steel with a thickness of 4 mm – in a vintage or satin finish – or metal. The welded square tube frames are always visible, thus underlining the exceptional solidity of the units.

Las encimeras Frame se ofrecen con cuatro superficies: acero Barazza de 4 mm de espesor en acabado Vintage o satinado, o en metal. La estructura en tubo cuadrado soldado siempre está a la vista y es una garantía de gran solidez.

Les plans de travail Frame sont proposés avec 4 options de revêtement : en acier Barazza de 4 mm d'épaisseur avec finition Vintage ou satinée, ou en métal. Le cadre, en tube carré soudé, est toujours apparent et est un gage de grande robustesse.

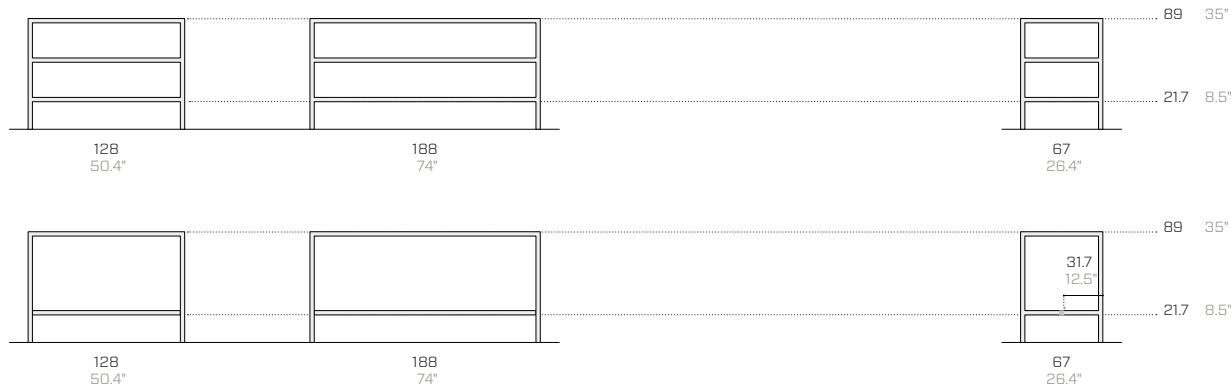

Frame

Tall units

Salvatore Indriolo, 2020

archiproducts
AWARDS
WINNER



Frame tall units are available in two widths and two heights, allowing for the free composition of doors, accessories, and appliances. There are no fewer than 35 different finishes on offer in the breathtaking colour palette, so the products can be customized to suit any setting.

Las columnas Frame se ofrecen en dos anchos y dos alturas, permitiendo la libre composición de puertas, accesorios y electrodomésticos. La sorprendente paleta de colores, compuesta por 35 acabados, permite personalizar el producto, adaptándolo a cualquier ambiente.

Les colonnes Frame sont proposées en deux largeurs et deux hauteurs, permettant la composition libre de portes, accessoires et appareils électroménagers. La palette de couleurs surprenante – déclinée en 35 finitions – vous permet de personnaliser le produit en l’adaptant à n’importe quel contexte.

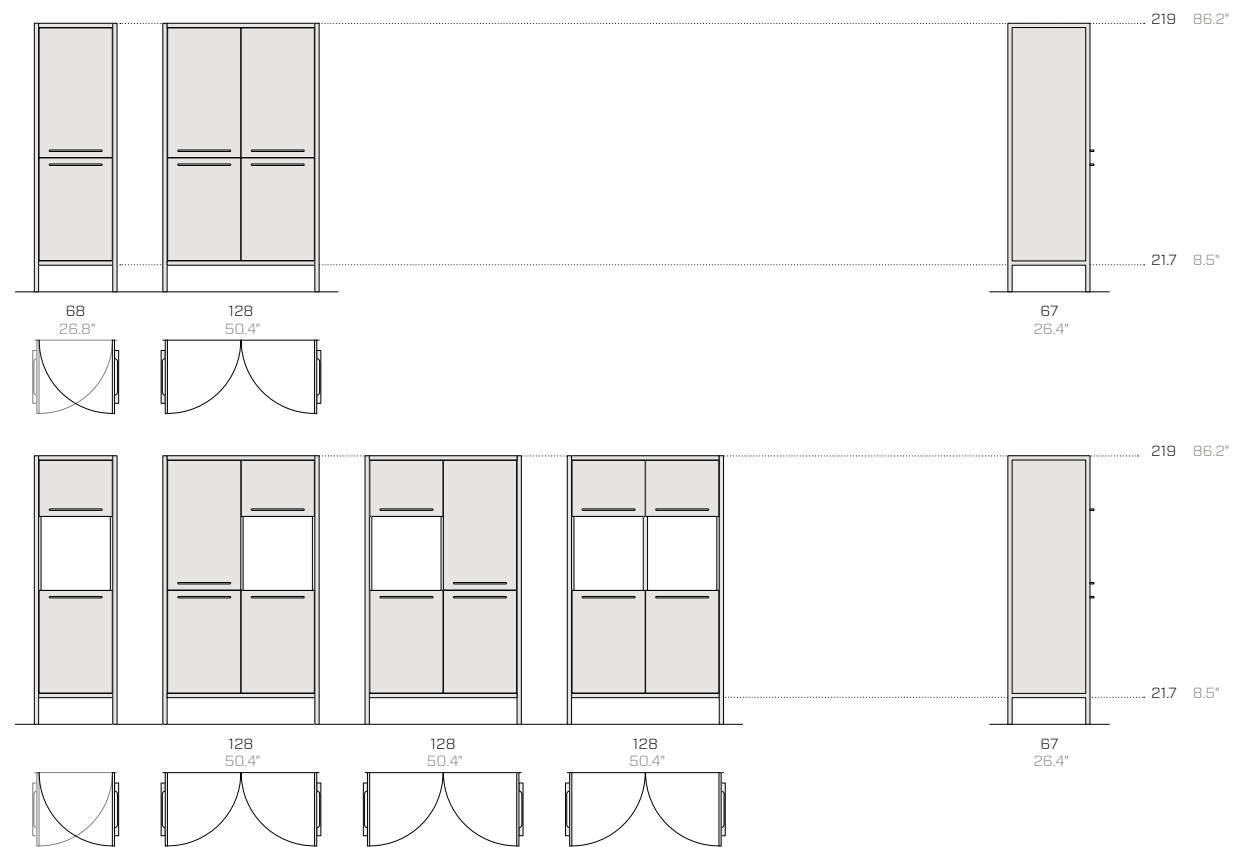





The compact Tall Units reach a height of just 173 cm and they are ideal for bridging the gap with living rooms. One way in which this can be done is with free-standing units. A range of appliances can be slotted into them, including ovens, microwaves, dishwashers, coffee machines and wine coolers.

Las Tall Units compactas tienen solo 173 cm de altura y son especiales como soluciones de continuidad hacia la sala, incluso en modalidad independiente. Permiten integrar electrodomésticos como hornos, microondas o lavavajillas, incluso la máquina de café y el botellero para el vino.

Les Tall Units compactes ne mesurent que 173 cm de haut. Idéales pour faire le lien avec les espaces de vie, elles existent aussi en version autoportante. Il est possible d'intégrer des appareils électroménagers tels que le four, le micro-ondes ou le lave-vaisselle, jusqu'à la machine à café et la cave à vin.



Frame Stools

Salvatore Indriolo, 2022

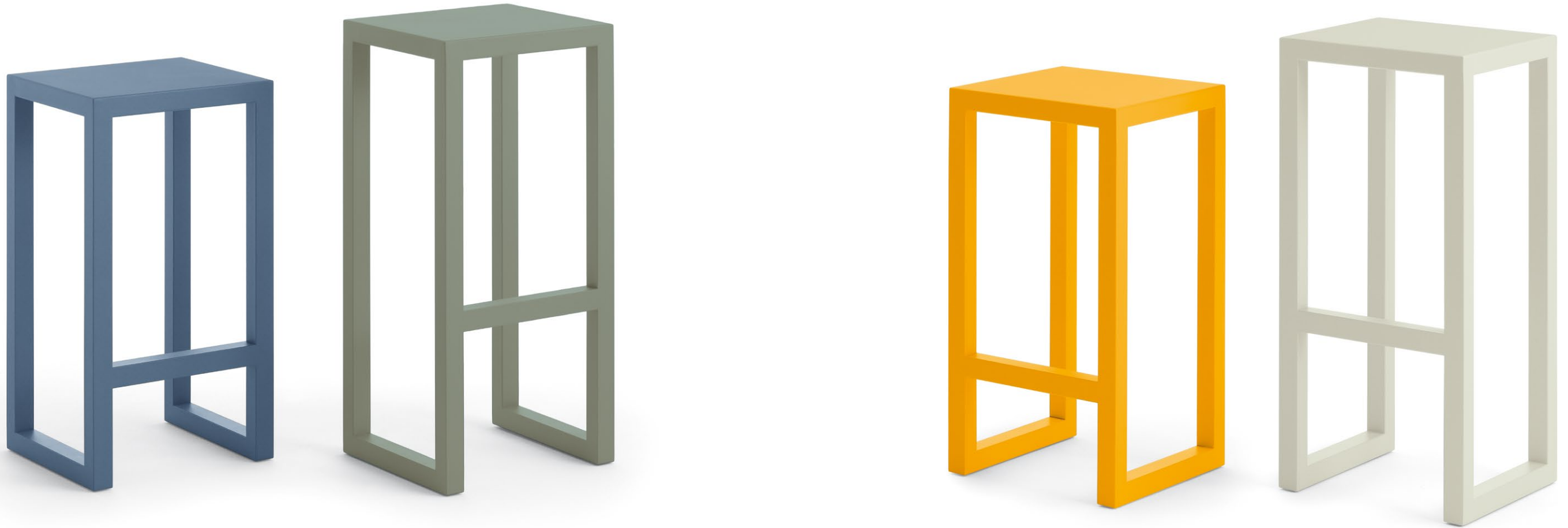

Frame stools have solid, iconic shapes. Ideal for use in conjunction with Frame Workbenches, they come in two heights and are highly versatile thanks to the range of 35 finishes in the broad colour palette, including 15 that are suitable for utilization both indoors and outdoors. They run the gamut from cloud grey for sophisticated, minimal style, to vibrant melon yellow for more eclectic locations.

Las banquetas Frame tienen una forma sólida e icónica. Pueden hacer juego con los Frame Workbenches, están disponibles en dos alturas y son un complemento de mobiliario transversal gracias a la amplia paleta de colores Fantin compuesta por 35 acabados, entre los cuales 15 son aptos también para exteriores, que van desde el gris nube, para un ambiente elegante y minimalista; hasta un energético amarillo melón, para los espacios más eclécticos.

Les tabourets Frame ont une forme solide et iconique. Pouvant être combinés avec les établis Frame, ils existent en deux hauteurs et sont un accessoire d'ameublement transversal grâce à la large palette de couleurs Fantin. Comprenant 35 finitions, dont 15 adaptées également pour l'extérieur, l'offre s'étend du gris nuage pour un environnement élégant et minimaliste au jaune melon vitaminé pour les espaces les plus éclectiques.

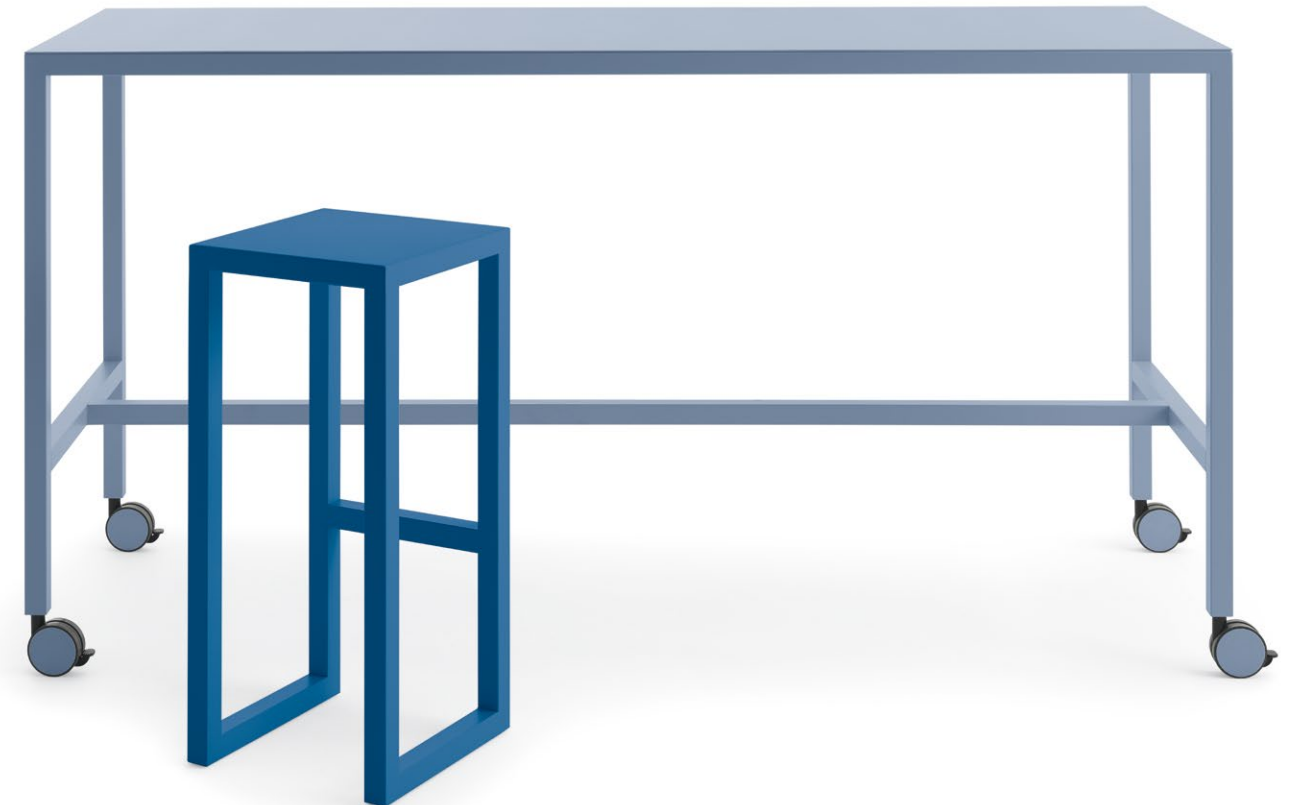
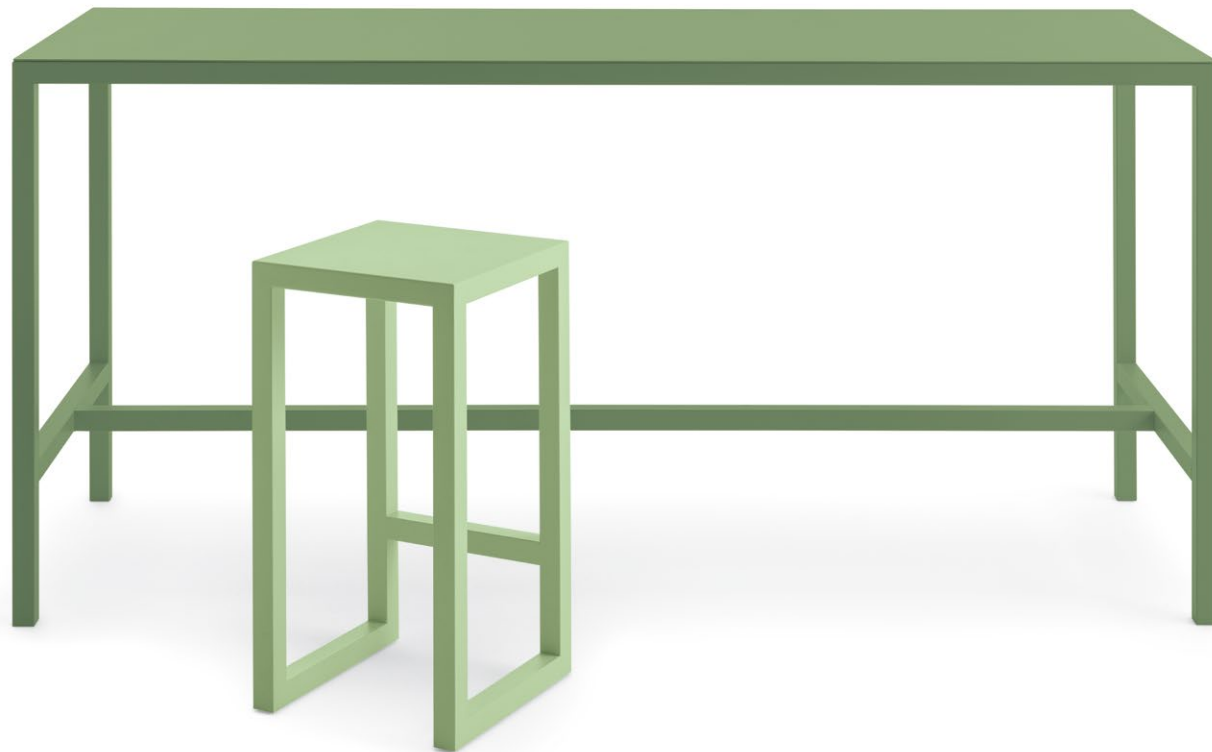
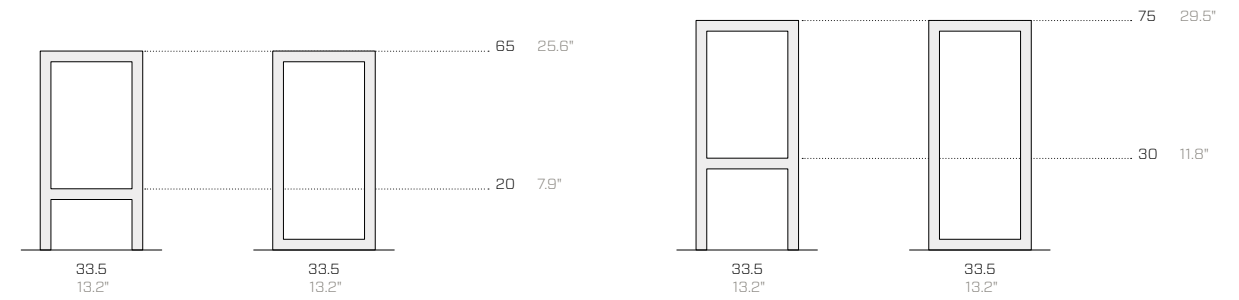



11.21

Melon yellow / Amarillo melón / Jaune melon

Embossed / Gofrado / Gaufré

Frame

Sideboards & cupboards

Salvatore Indriolo, 2018





The Frame collection of sideboards and cupboards features a minimal design, with square tube frames that are always visible. The slender tops are just a few millimetres thick and it is made of metal, as are the two different types of doors: solid and perforated. They provide the scope for a range of modular solutions and the variety of compositions – together with the breathtaking selection of 35 Fantin finishes – means that the collection is ideally suited to all settings.

La colección Frame de aparadores y armarios se caracteriza por un diseño minimalista, en el cual la estructura en tubo cuadrado es visible siempre. El tablero, de unos milímetros de espesor, es de metal, al igual que las dos versiones de puertas, ciega y perforada, las cuales permiten diferentes composiciones sobre los distintos módulos, haciendo que la colección sea apta en cualquier contexto, junto a la sorprendente oferta de 35 acabados Fantin.

La collection de buffets et de crédences Frame se caractérise par un design minimaliste où le cadre en tube carré est toujours apparent. Le plan de travail, de seulement quelques millimètres d'épaisseur, est en métal tout comme les deux versions de portes : pleine et perforée. Celles-ci permettent plusieurs compositions en jouant avec les différentes solutions modulaires, ce qui rend la collection adaptée à tous les contextes, grâce aussi au choix surprenant des 35 finitions Fantin.

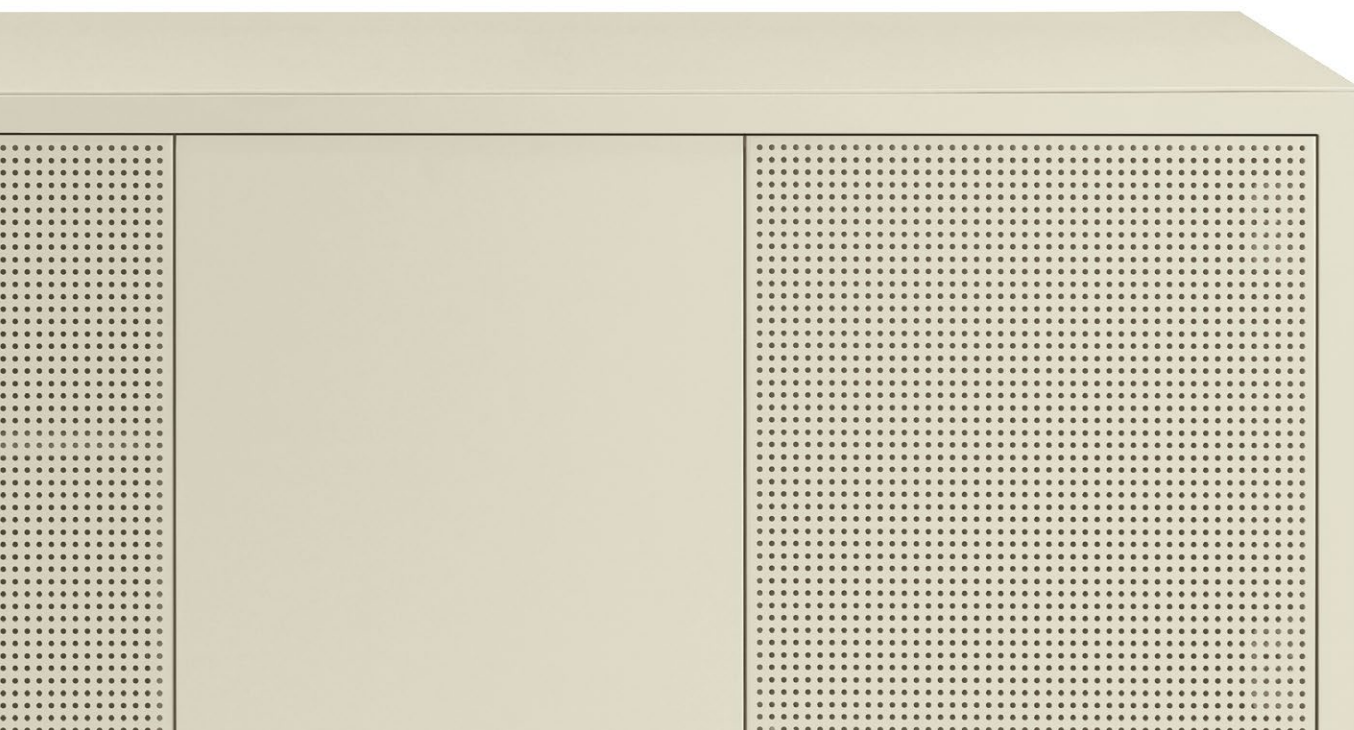





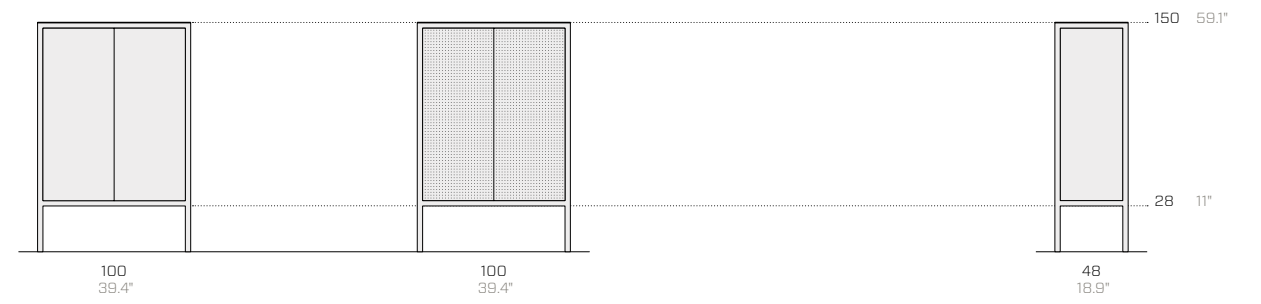



Frame

Beds

Salvatore Indriolo, 2022



The beds and bases in the Frame selection have the trademark square tube running around the bottom of the mattress and solid lower sides for secure frame support, with housing inset by 7 cm or 12 cm. The visible frame running around the perimeter also takes in the headboard, which can be made of metal or soft padded fabric. The beds can be complemented by two different accessories: integrated overhanging bedside tables and a back for the headboard, for striking free-standing solutions. The combination of the minimal design and the 35 finishes in the Fantin palette mean that Frame Beds are suitable for use not only at home but also in accommodation facilities.

Las camas y somieres del programa Frame se caracterizan por un armazón en el característico tubo cuadrado y unos bordes inferiores sólidos que ofrecen un soporte seguro a los somieres, con un marco de 7 o 12 cm. El cabecero está rodeado de un marco perimetral visible, en metal o en tapicería suave acolchada. Los complementos que enriquecen la oferta son las mesitas de noche flotantes integradas y el respaldo para el cabecero, para soluciones independientes de alto impacto. Los 35 acabados de la paleta Fantin, aplicados al diseño minimalista, hacen que las camas Frame sean aptas tanto para el hogar como para la hostelería.

Les lits et les sommiers du programme Frame se distinguent par un cadre de lit constitué du tube carré caractéristique et de solides bords inférieurs pour un support sûr des sommiers, avec un encastrément de 7 ou 12 cm. La tête de lit est toujours logée dans le cadre périphérique apparent et est proposée en métal ou dans un moelleux tissu rembourré. L'offre est enrichie par les chevets intégrés en porte-à-faux et le dossier de la tête de lit, pour des solutions autoportantes à fort impact. Grâce aux 35 finitions de la palette Fantin, appliquées au design minimaliste, les lits Frame conviennent aussi bien à la maison qu'aux solutions d'hébergement.





61.24 Pale Gold



52.18 Moss



43.21 Bronze



47.21 Platinum + T1.22 Smoke



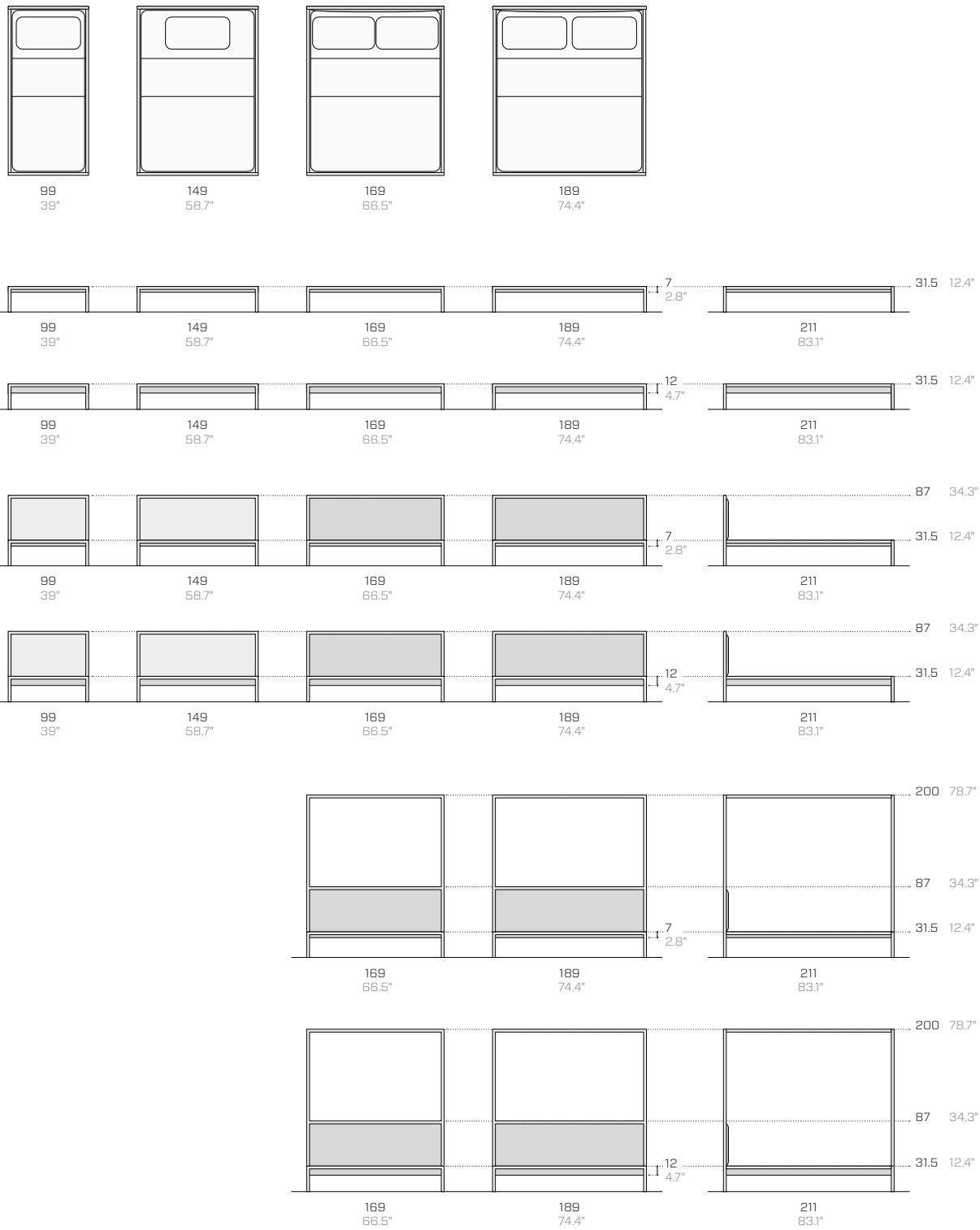



Frame

Tables & desks

Salvatore Indriolo, 2018



Selezione Compasso d'Oro



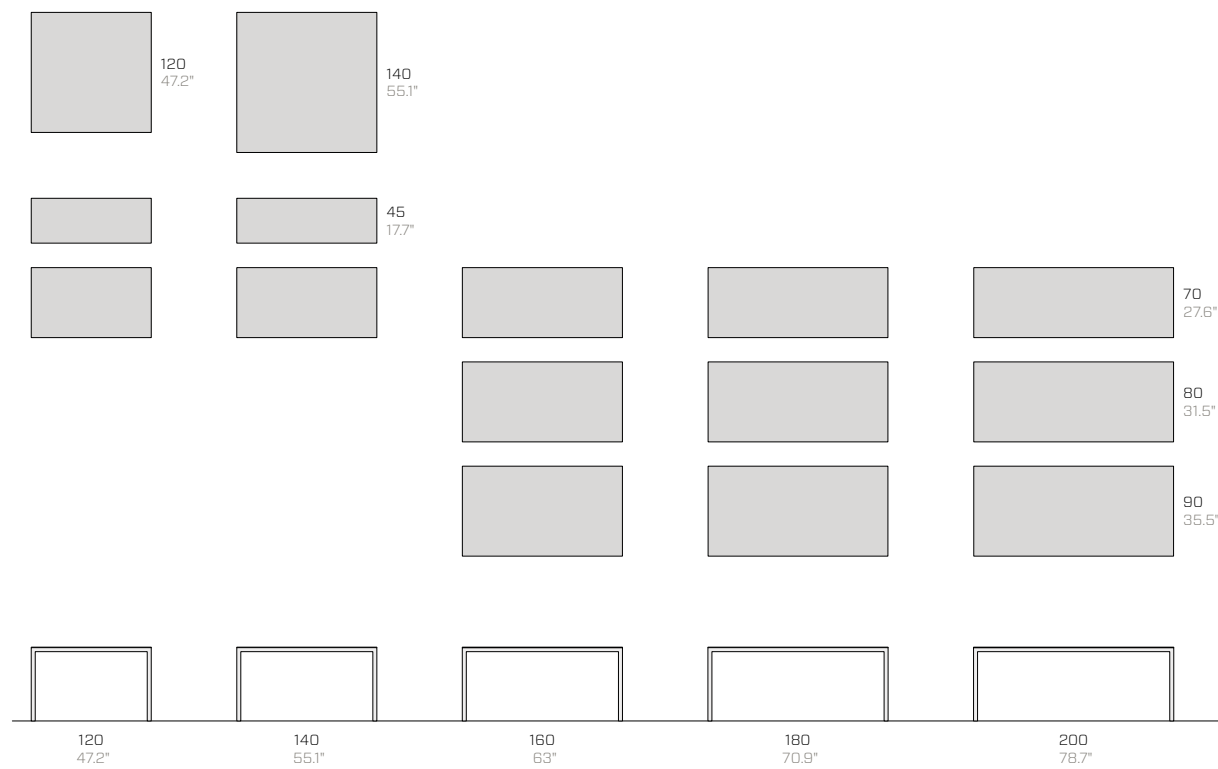

The key distinguishing feature of the minimal design for the Frame tables and desks is the relationship between the solid square tube frames and the extremely slender tops. In addition, the items are made of metal, so all of the Fantin finishes are available and the collection is suitable for use in all settings.

En el diseño minimalista de las mesas y escritorios Frame, el rasgo distintivo real es la entre la sólida estructura en tubo cuadrado y la tapa muy delgada. Además, el uso del metal permite contar con un objeto realizado con un único material que se puede presentar en los distintos acabados Fantin, lo que hace que esta colección sea apta para todos los ambientes.

Relativement au design minimaliste des tables et des bureaux Frame, le véritable élément distinctif est la relation entre le cadre solide en tube carré et le plateau de très faible épaisseur. Par ailleurs, l'utilisation du métal permet d'avoir un objet monomatière qui peut être décliné dans toutes les finitions Fantin, ce qui rend cette collection adaptée à tous les contextes.







Hug

Tables & stools

Giulio Iacchetti, 2022-23

archiproducts
AWARDS
WINNER
SUSTAINABILITY



Joints play a crucial part in structures of all kinds: although they are not usually conspicuous and sometimes not even visible at all, they give stability and solidity. The design deliberations behind Hug tables revolved around them. The frame literally hugs the legs, clinching them in the curves running around its outline. The joints comprehensively perform their structural role while also giving the tables a highly distinctive look. In addition, its position within easy reach just under the table top means that the frame also serves another purpose by supporting a selection of three accessories that can be moved around and attached freely: a bag hanger, a tray and a pen holder.

En cualquier tipo de estructura, las uniones representan un elemento crucial, pues, aunque son poco visibles o a veces ocultas, garantizan estabilidad y solidez. En ellas se centra el análisis del diseño para las mesas Hug: el marco abraza literalmente las patas, insertadas en sus curvas perimetrales. Las uniones cumplen la función estructural de forma plena, confiriendo a la mesa una gran connotación estética. Además, el marco, gracias a su posición al «alcance de la mano», justo debajo del tablero, cumple una función adicional, pues sirve de soporte a una serie de tres accesorios: un gancho para bolsos, una bandeja y un portaplumas que se pueden enganchar y mover libremente.

Les jointures sont un élément crucial de tout type de structure : bien que peu visibles ou parfois cachées, elles confèrent stabilité et solidité à l'ensemble. C'est sur celles-ci que s'est axée la pensée du designer pour les tables Hug : le cadre enveloppe littéralement les pieds, les enserrant dans les courbes de son contour. Les jointures remplissent pleinement leur rôle structurel tout en donnant à la table une forte connotation esthétique. Par ailleurs, grâce à sa position « à portée de main », juste sous le plateau, le cadre remplit une autre fonction, à savoir celle de support pour un kit de trois accessoires – un crochet porte-sac, un plateau et un porte-stylos – qui peuvent être accrochés et déplacés à volonté.





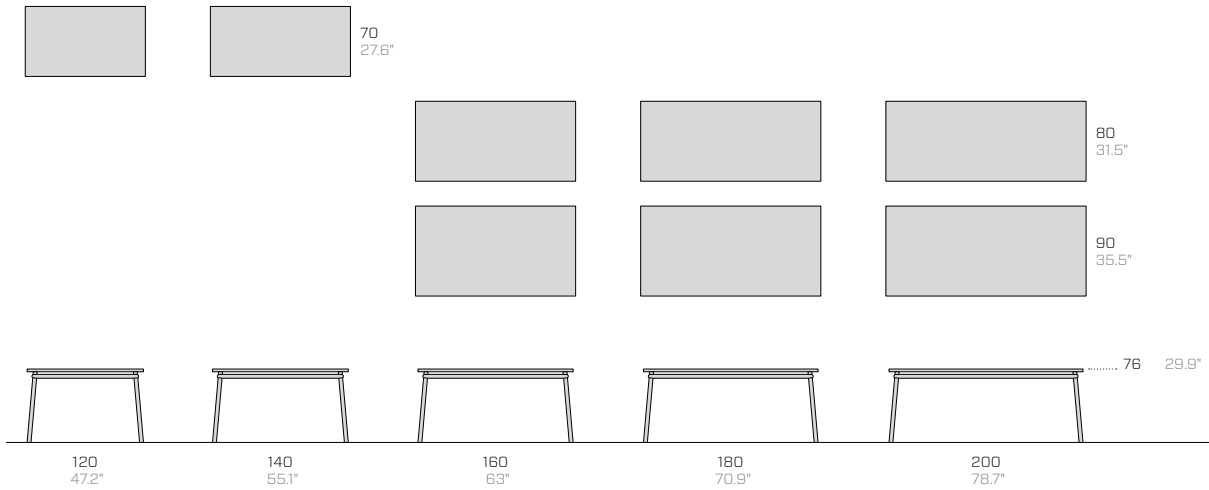
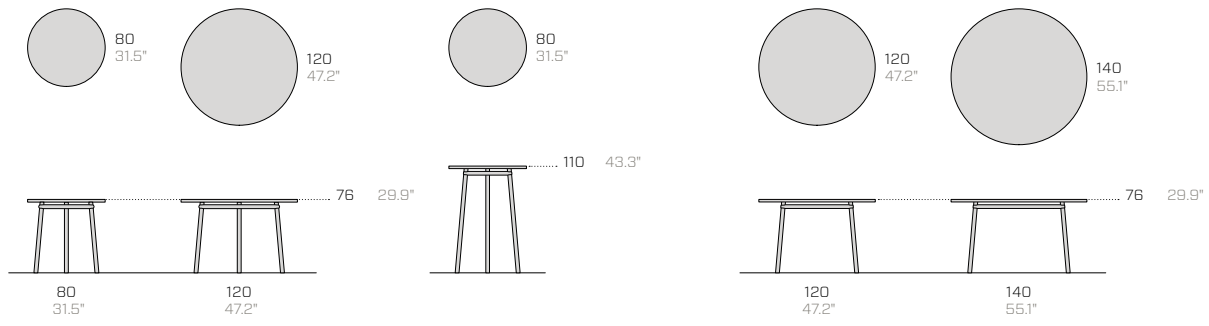



Hug stools extend Giulio lacchetti's collection for Fantin. With a 35 cm circular seat and three heights – 47, 65 and 75 cm – they provide both comfort and style. The distinctive junction between legs and frame forms three symbolic “hugs” ensuring structural stability and a unique aesthetic. Customizable in 35 non-toxic colors, Hug stools are a versatile solution, perfect for indoor and outdoor environments.

Los taburetes Hug amplían la colección de Giulio lacchetti para Fantin. Con un asiento circular de 35 cm y tres alturas: 47, 65 y 75 cm, ofrecen comodidad y estilo. La particular unión entre las patas y el marco forma tres "abrazos" simbólicos, garantizando estabilidad estructural y una estética única. Personalizables en 35 colores no tóxicos, los taburetes Hug son una solución versátil, perfecta para ambientes interiores y exteriores.

Les tabourets Hug étendent la collection de Giulio lacchetti pour Fantin. Avec une assise circulaire de 35 cm et trois hauteurs – 47, 65 et 75 cm – ils offrent à la fois confort et style. La jonction distinctive entre les pieds et le cadre forme trois "étreintes" symboliques, assurant stabilité structurelle et esthétique unique. Personalisables en 35 couleurs non toxiques, les tabourets Hug sont une solution polyvalente, parfaite pour les espaces intérieurs et extérieurs.

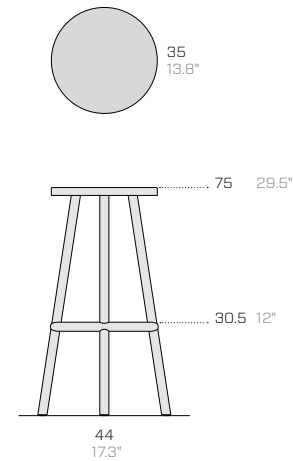
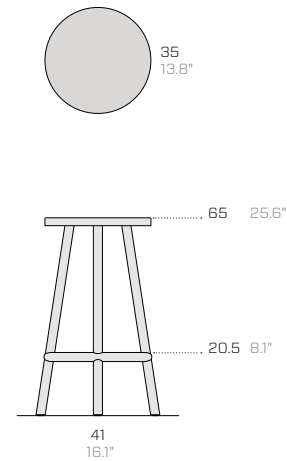
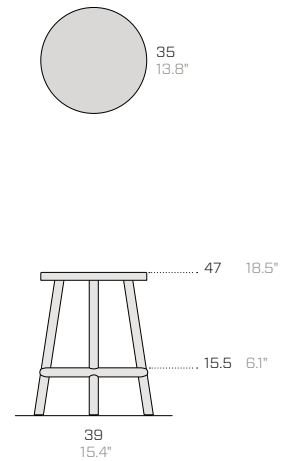

Hug Hangers

Giulio Iacchetti, 2024

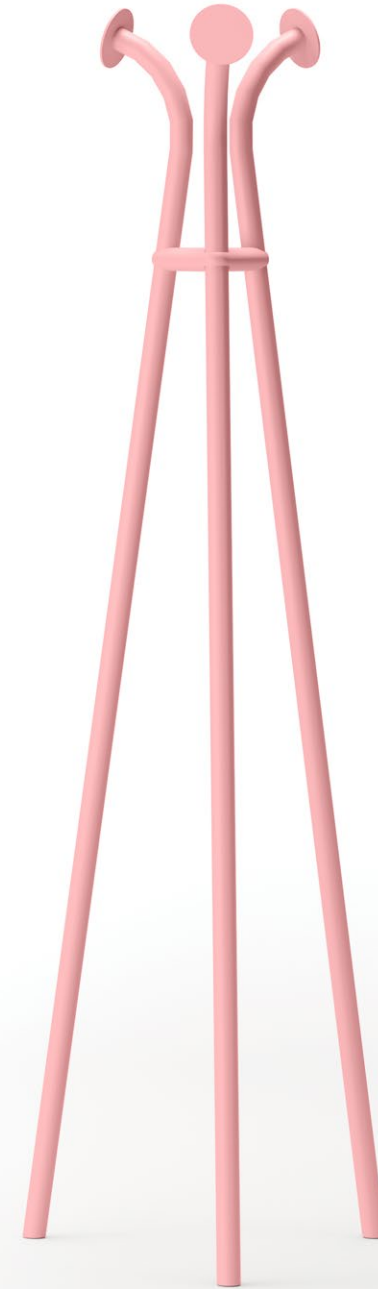

The Hug collection is enriched with a series of wall and floor coat racks, characterized by large metal discs and customizable with all the colors of the Fantin palette. Simple and linear elements, for a contemporary and carefree living.

La colección Hug se enriquece con una serie de percheros de pared y de suelo, caracterizados por grandes discos de metal y personalizables con todos los colores de la paleta Fantin. Elementos simples y lineales, para una vida contemporánea y despreocupada.

La collection Hug s'enrichit d'une série de porte-manteaux murales et sur pied, caractérisée par de grands disques en métal et personnalisable avec toutes les couleurs de la palette Fantin. Des éléments simples et linéaires, pour une vie contemporaine et insouciante.

Single hanger / Perchero individual / Porte-manteau simple

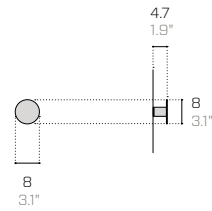

Hatbox / Perchero para sombreros / Porte-chapeaux

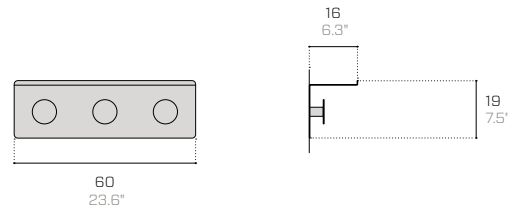

Floor coat hanger / Perchero de suelo / Porte-manteau au sol

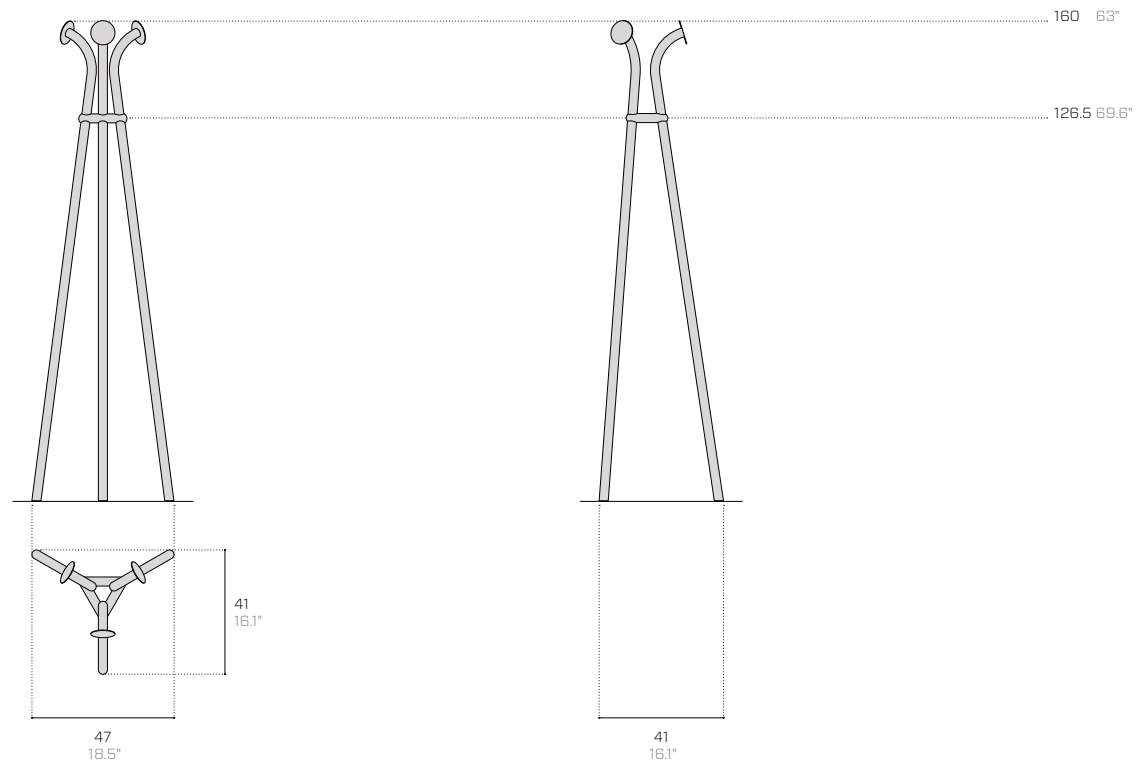

Wave

Desks & add-ons

ruga.perisinotto, 2024



Wave is a collection of accessories that uses the curve as a decorative and functional element of the object.

The volumes, almost two-dimensional, are made by bending sheets of metal, employing a characteristic production method always present in Fantin.

The collection consists of a desk, shelves, and bookends.

Wave es una colección de complementos que utiliza la curva como elemento decorativo e identificativo de la funcionalidad del objeto.

Los volúmenes, casi bidimensionales, están hechos mediante el doblado de hojas de metal, utilizando una característica de producción que siempre ha estado presente en Fantin.

La colección se compone de un escritorio, estantes y sujetalibros.

Wave est une collection d'accessoires qui utilise la courbe comme élément décoratif et fonctionnel de l'objet.

Les volumes, presque bidimensionnels, sont réalisés en pliant des feuilles de métal, en utilisant une méthode de production caractéristique toujours présente chez Fantin.

La collection se compose d'un bureau, de étagères et de serre-livres.

Desks with drawer / Escritorios con cajón / Bureaux avec tiroir

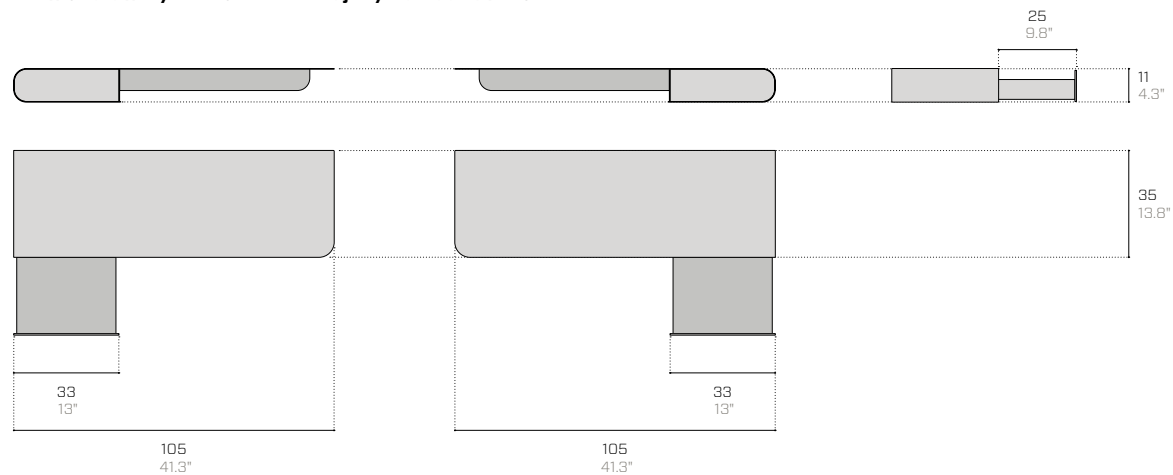

Shelves with side / Estantes con lateral / Étagères avec côté

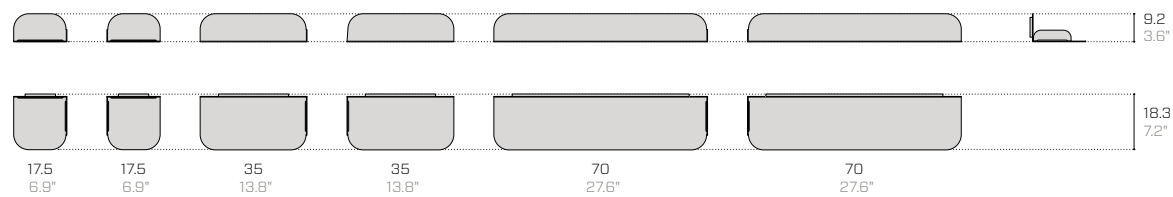

Bookend / Sujetalibros / Serre-livres

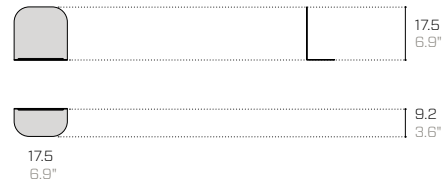

Bookend with side / Sujetalibros con lateral / Serre-livres avec côté



Wave bookend kit / Kits de sujetalibros ondulados / Kits de serre-livres ondulés



Still

Sandro Fantin, 2014

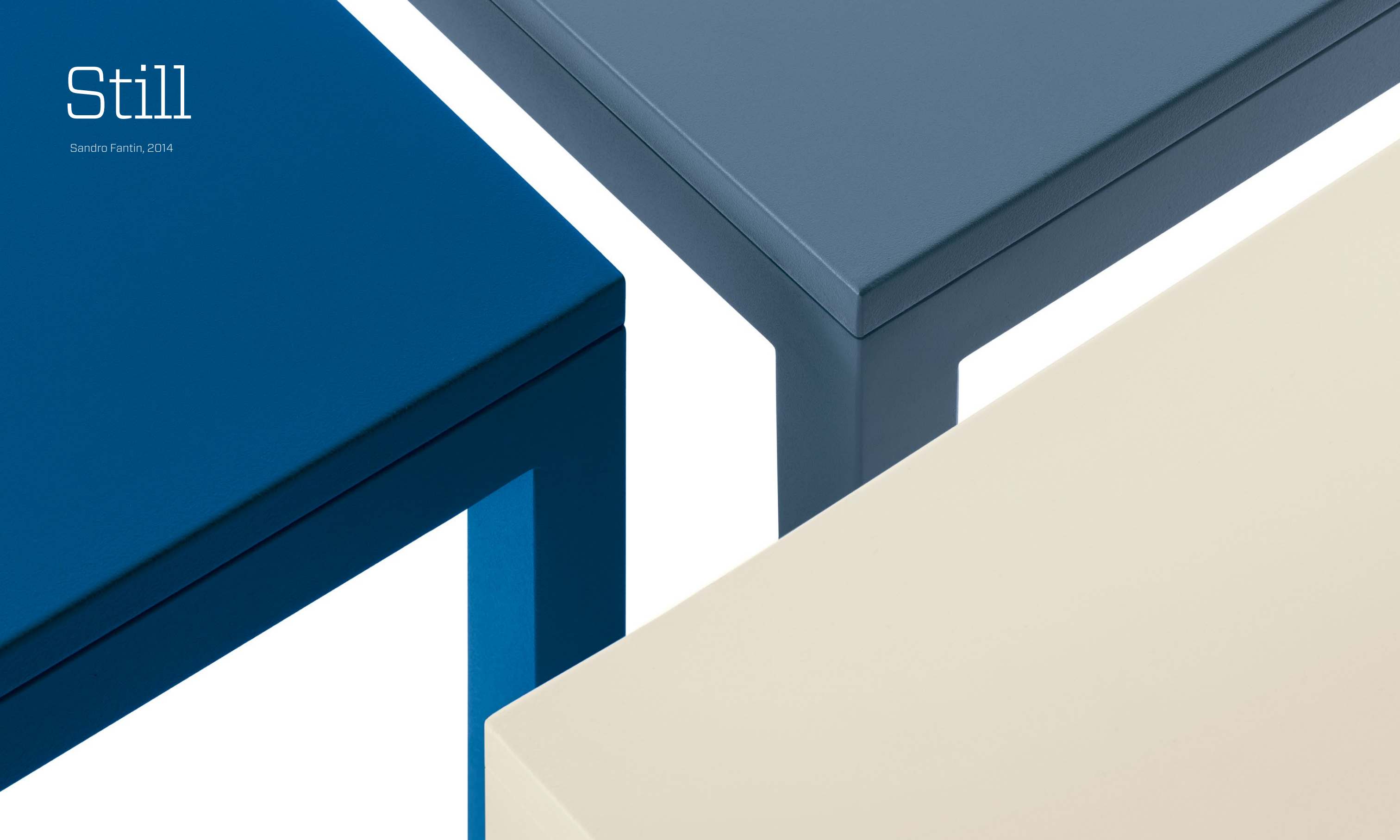

The design of the Still table emphasizes its great solidity, which is its main feature. It has pure, simple lines and the structure supporting the top is made of square tubes. It is made from metal, so it has been possible to produce a mono-material object that is available with all of the colour options for the Fantin collection.

El diseño de la mesa Still evoca su característica más importante: una gran solidez. Caracterizado por líneas simples y rigurosas, está compuesto por una estructura tubular cuadrada que soporta el tablero. El uso del metal permite contar con un objeto de material único, en todas las variaciones cromáticas de la colección Fantin.

Le design de la table Still souligne sa grande solidité, qui est sa principale caractéristique. Elle présente des lignes épurées et simples et la structure qui soutient le plateau est faite de tubes carrés. L'utilisation du métal permet d'avoir un objet mono-matière, dans toutes les variantes chromatiques de la collection Fantin.



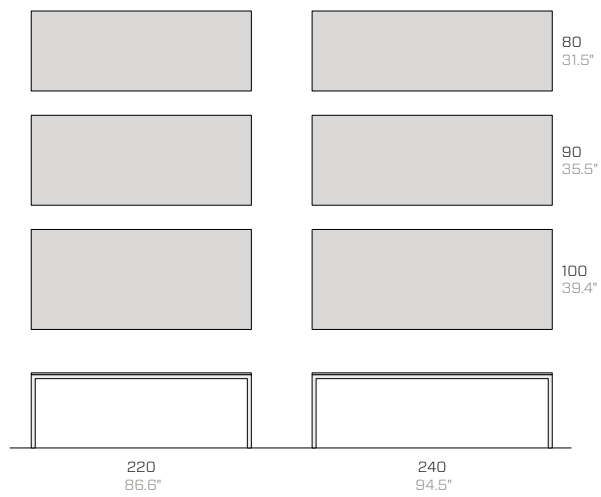
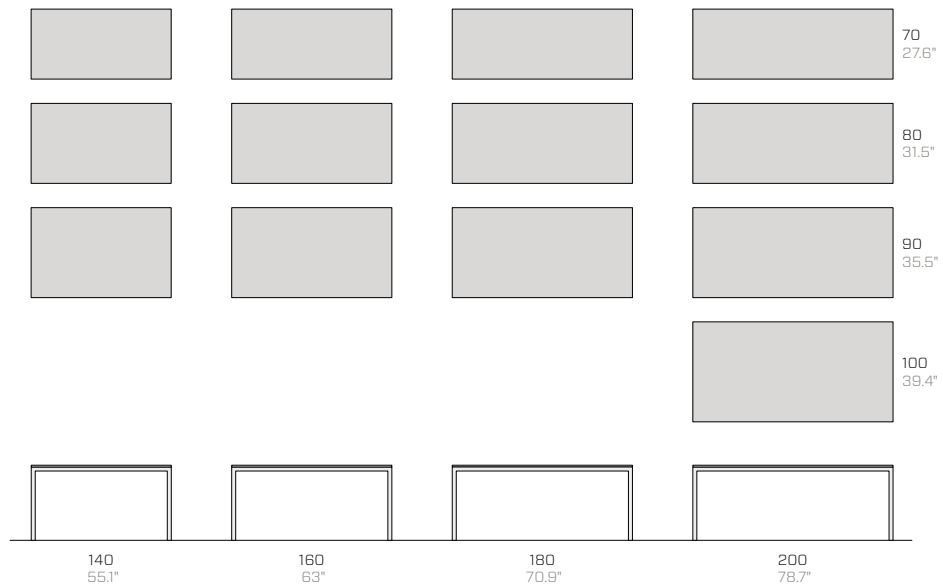
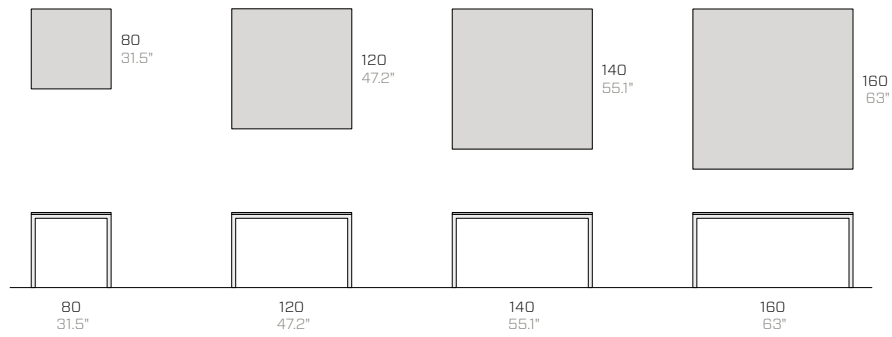





Uno

Dorino Fantin, 1973



Solid modularity: Uno is a versatile and potentially infinite system. The click-fastening assembly system means extended shelving systems can be put up in no time, safely and without the use of screws or bolts. The reinforced shelves are built to withstand heavy loads and, when placed side-by-side, they guarantee convenient continuity. A host of accessories and a broad range of colours mean that Uno can be used in any setting and, when you move, the system can be taken down and adapted to the new environment, even in different configurations. It is also available with LED lighting.

Modularidad sólida. Uno es un sistema versátil y potencialmente infinito. El sistema de ensamblaje con ganchos permite montar estantes muy grandes en poco tiempo, de forma segura y sin el uso de tornillos o pernos. Los planos reforzados permiten soportar cargas pesadas y, si se colocan uno al lado del otro, garantizan una cómoda continuidad. Numerosos accesorios y una amplia gama de colores permiten utilizar Uno en cualquier ambiente y, en caso de mudanza, el sistema se puede desmontar y adaptar al nuevo contexto, incluso con diferentes configuraciones. También está disponible con iluminación LED.

Modularité solide: Uno est un système polyvalent et potentiellement illimité. Le système d'assemblage à crochets vous permet de monter de très grandes étagères rapidement, en toute sécurité et sans besoin de vis ni de boulons. Les surfaces renforcées permettent de supporter de lourdes charges et, lorsqu'elles sont montées côte à côte, elles garantissent une continuité très pratique. Les nombreux accessoires et la large gamme de couleurs vous permettent d'utiliser Uno dans n'importe quel contexte. En outre, en cas de déménagement, le système peut être démonté et adapté au nouvel environnement, même dans des configurations différentes. Il est également disponible avec un éclairage LED.

Uprights / Montantes / Montants

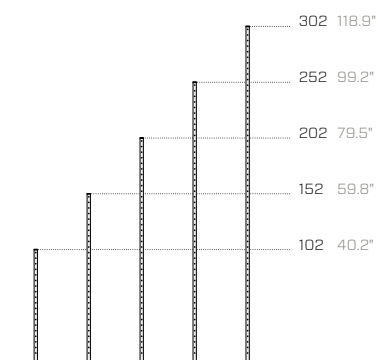

Slot pitch / Paso de agujeros / Pas des trous = 5 cm (1.9")

Shelves / Estantes / Étagères









ESTINTORE
N°



Uno living

Dorino e Sandro Fantin, 2017



This modular bookcase is made entirely of metal. Fantin's long-standing fastener-based shelving system has been complemented by the addition of overhanging shelves, allowing all settings to be furnished optimally, with boundless versatility.

Biblioteca modular totalmente de metal. El histórico sistema de estantes con ganchos Fantin se enriquece gracias a la incorporación de estantes colgantes, los cuales permiten amueblar de la mejor manera posible y con una versatilidad ilimitada.

Bibliothèque modulaire entièrement en métal. Le système historique d'étagères à crochets Fantin est enrichi par l'ajout d'étagères en porte-à-faux, qui vous permettent un agencement optimal et une polyvalence illimitée.

Uprights / Montantes / Montants

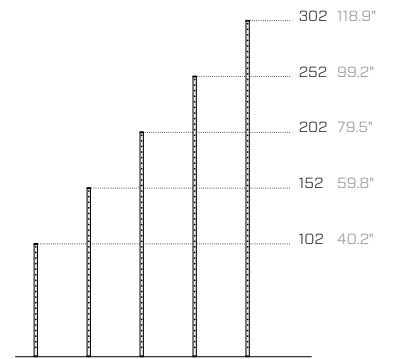

Slot pitch / Paso de agujeros / Pas des trous = 5 cm (1.9")

Standard shelves / Estantes estándar / Étagères standard

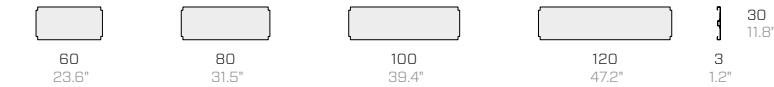

Overhanging shelves / Estantes colgantes / Étagères en porte-à-faux

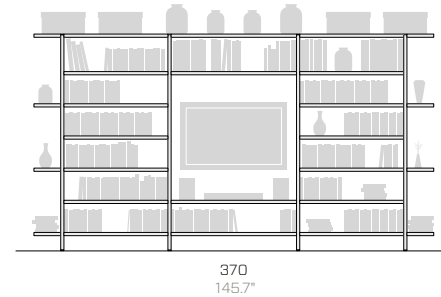
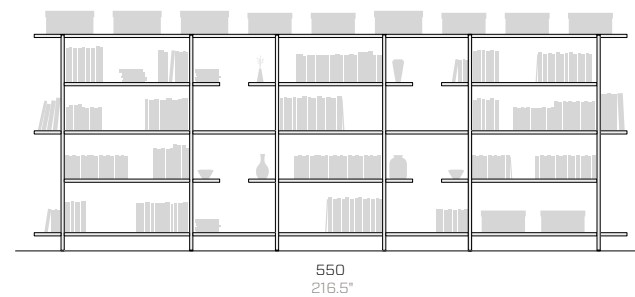
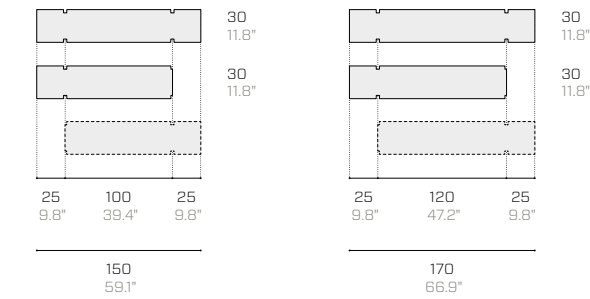

Ali

Salvatore Indriolo, 2016





The drawer units and cabinets in the Ali Collection have distinctive handle grips which not only serve a simple practical purpose but also add aesthetic appeal. The design concept is based on the idea of a series of drawers and doors that are punctuated by the nuances of lights and shadows. The numerous size options mean that the Ali Collection is suitable for all settings.

La colección Ali se compone de cajoneras y armarios, caracterizados por la manija particular que de ser un simple elemento funcional pasa a ser un elemento estético. La serie de cajones o puertas, caracterizada por los matices de luces y sombras, es la base del concepto de diseño. Las distintas variaciones dimensionales hacen que la colección Ali sea apta para todos los ambientes.

Ali Collection est composée de caissons à tiroirs et de crédences, caractérisés par une poignée particulière qui transforme un simple élément fonctionnel en un élément esthétique. Le concept de design est basé sur l'idée d'une succession de tiroirs ou de portes, rythmée par des nuances d'ombre et de lumière. Grâce aux nombreuses options de taille, Ali Collection s'adapte à tous les espaces.

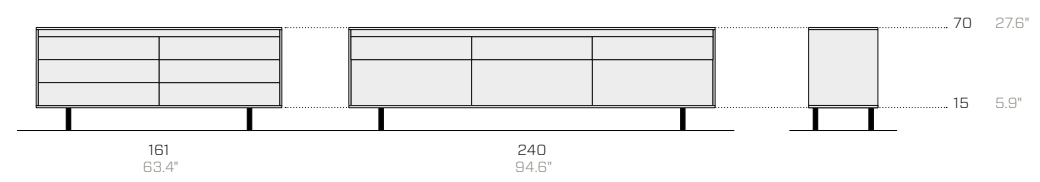
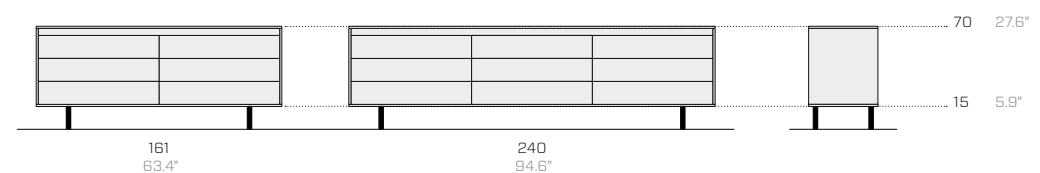
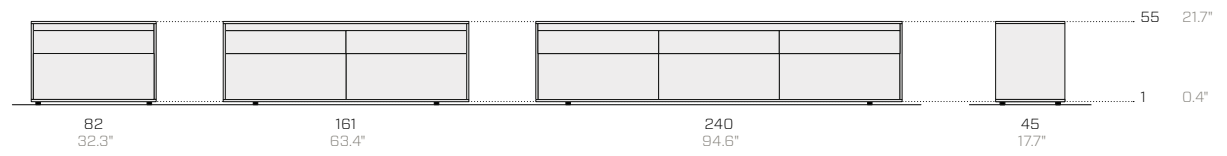
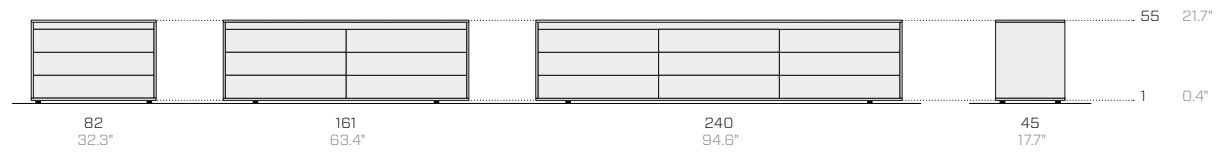



Just

Salvatore Indriolo, 2016

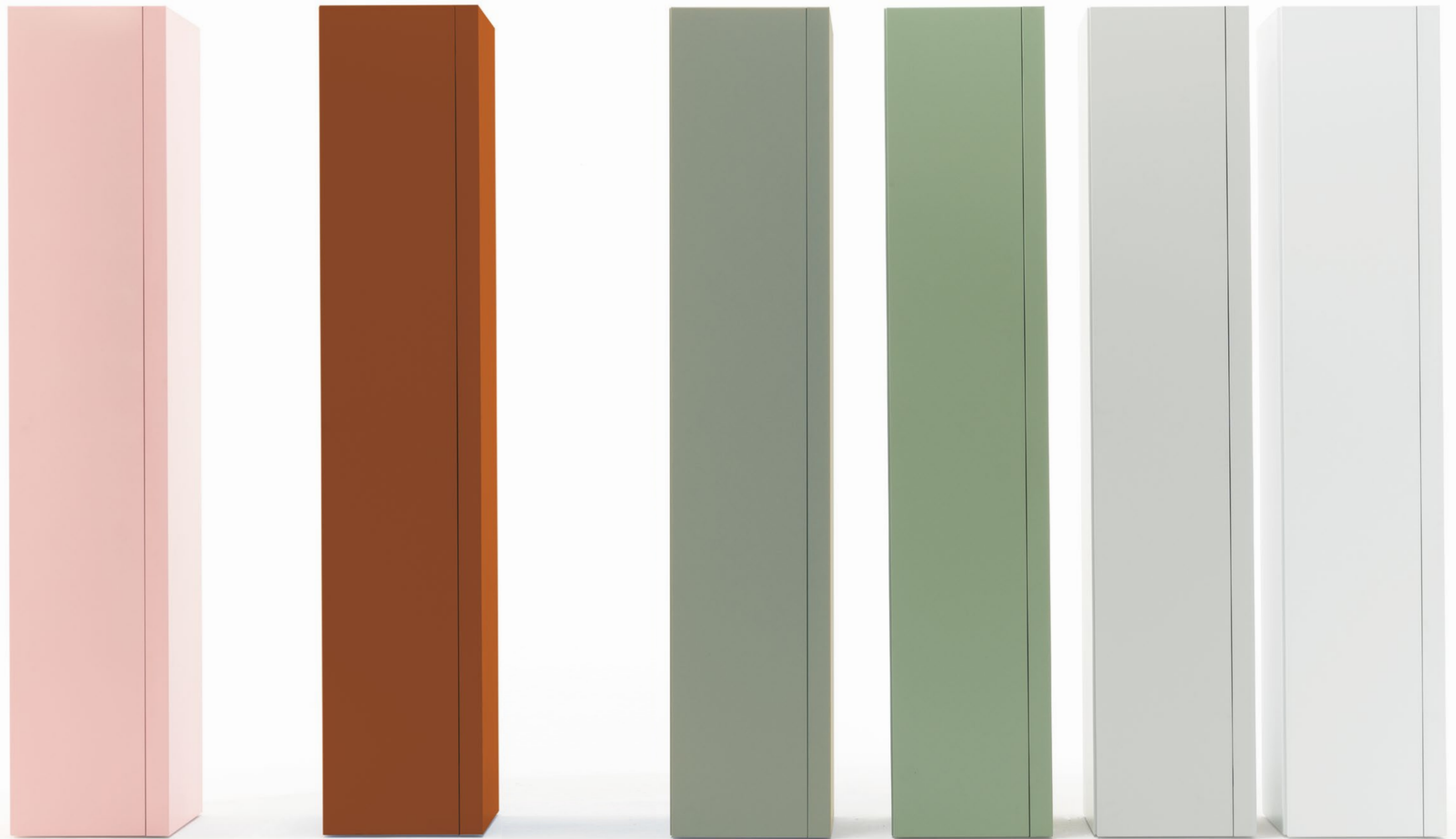

Just takes the classic locker concept to the next level with its contemporary design that is marvelously complemented by every colour in the Fantin range. Great attention to detail is apparent not only in Just's aesthetic appeal but also in its practical solutions. For example, a large number of shelves can be used and freely positioned and the doors can be opened on either the right or the left. The lockers are durable, discreet and suitable for all public and private purposes.

Just es la evolución del clásico gabinete, ya que se enriquece con un diseño contemporáneo realzado con todos los colores de la gama Fantin. Además de la atención al detalle estético, Just presenta diversas soluciones prácticas, como la posibilidad de contar con muchos estantes que se pueden colocar libremente, además de abrir las puertas tanto por la derecha como por la izquierda. Sólido y discreto, se adapta a todas las necesidades tanto públicas como privadas.

Just est l'évolution du meuble de rangement classique, car il s'enrichit d'un design contemporain qui est mis en valeur par toutes les couleurs de la gamme Fantin. En plus de l'attention portée aux détails au niveau du design, Just présente plusieurs solutions pratiques, telles que la possibilité d'avoir de nombreuses tablettes pouvant être positionnées librement et d'ouvrir les portes à droite ou à gauche. Solide et discret, il s'adapte à tous les usages publics et privés.

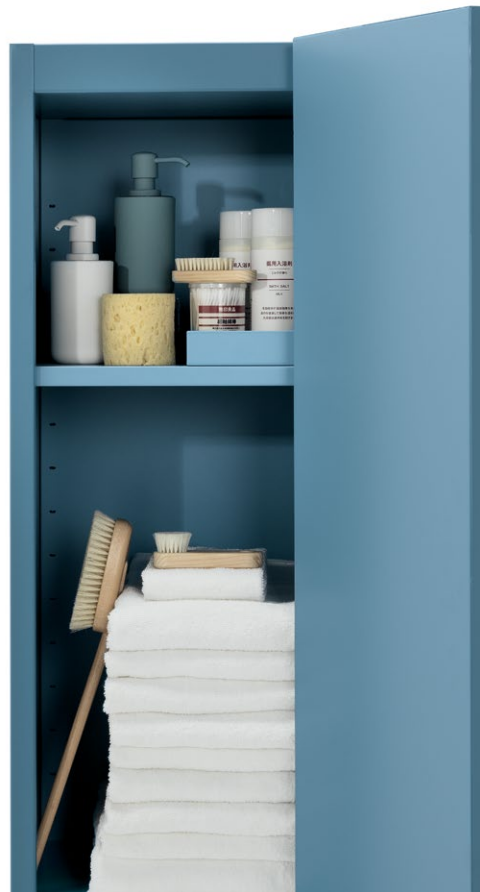

Just One Push Pull

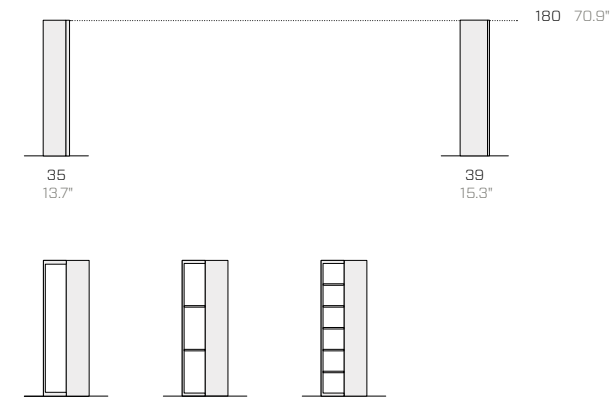

Just One Key

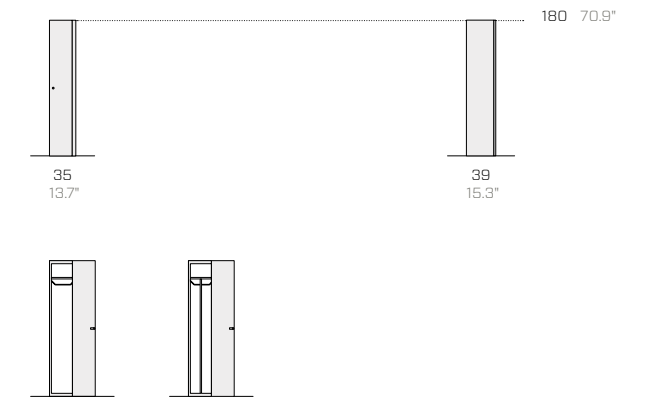

Just Two

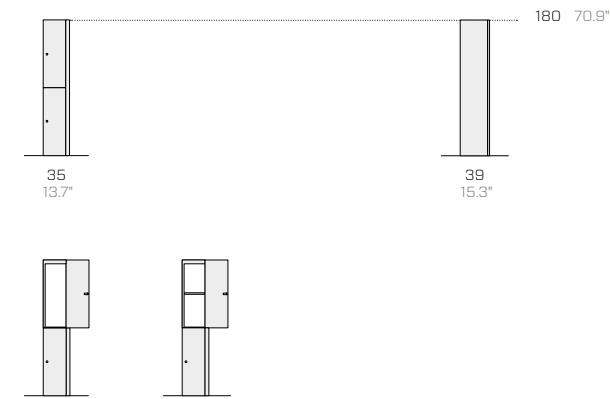

Just Four

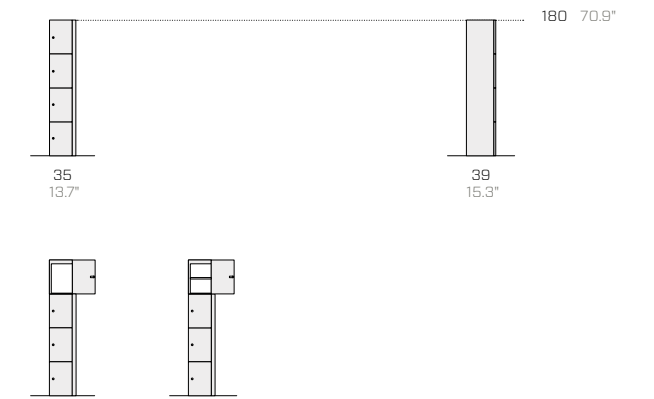



Cambio

Dorino Fantin, 1980



Cambio changing room lockers provide a rational solution for the safekeeping of personal items in communal and operational areas. Practical and sturdy, they come in endless combinations thanks to the ample colour customisation opportunities and to the variety of models with varying storage capacities.

Los armarios de vestuario y casilleros Cambio son una solución racional para guardar y proteger los objetos personales en espacios comunes y operativos. Prácticos y robustos, cuentan con infinitas combinaciones gracias a la amplia personalización de colores y a la variedad de modelos con distintas capacidades de almacenamiento.

Les vestiaires Cambio sont la solution rationnelle pour un rangement sécurisé des effets personnels dans les espaces collectifs et de travail. Pratiques et robustes, ils se déclinent en une infinité de combinaisons grâce aux nombreuses possibilités de personnalisation des couleurs et à la variété des modèles aux capacités de rangement variables.





Standard

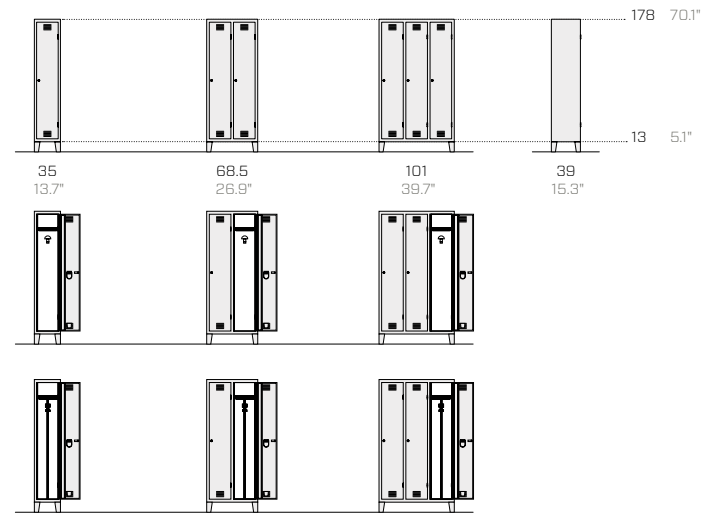

Plus

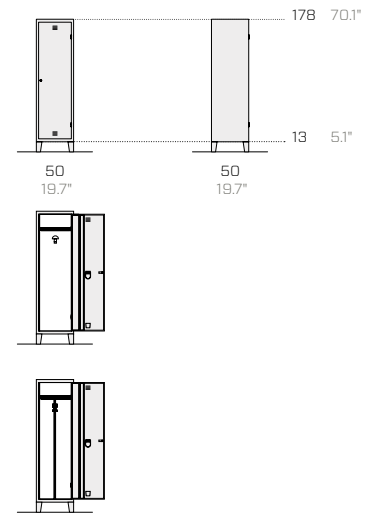

Palestra

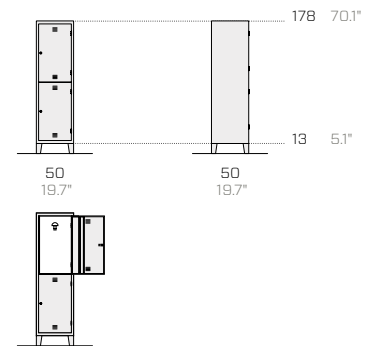
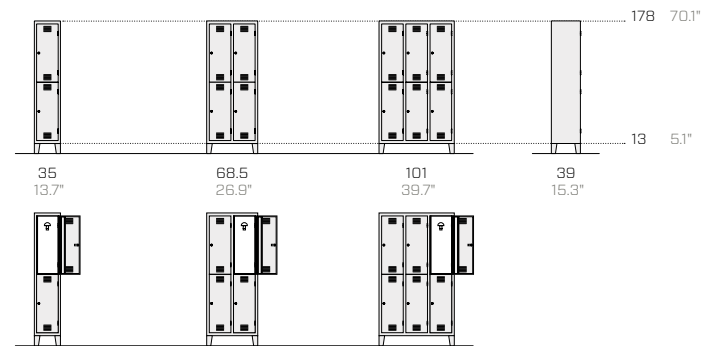

Casellario

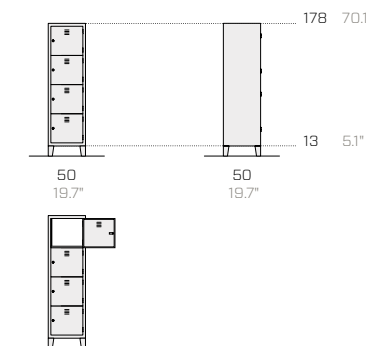
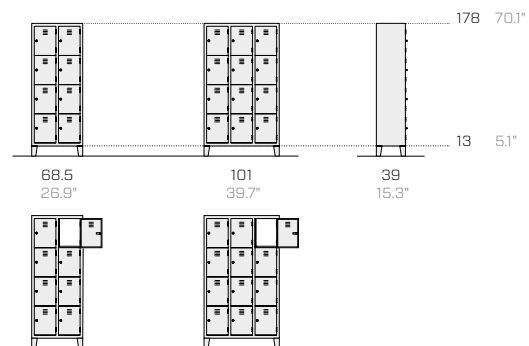

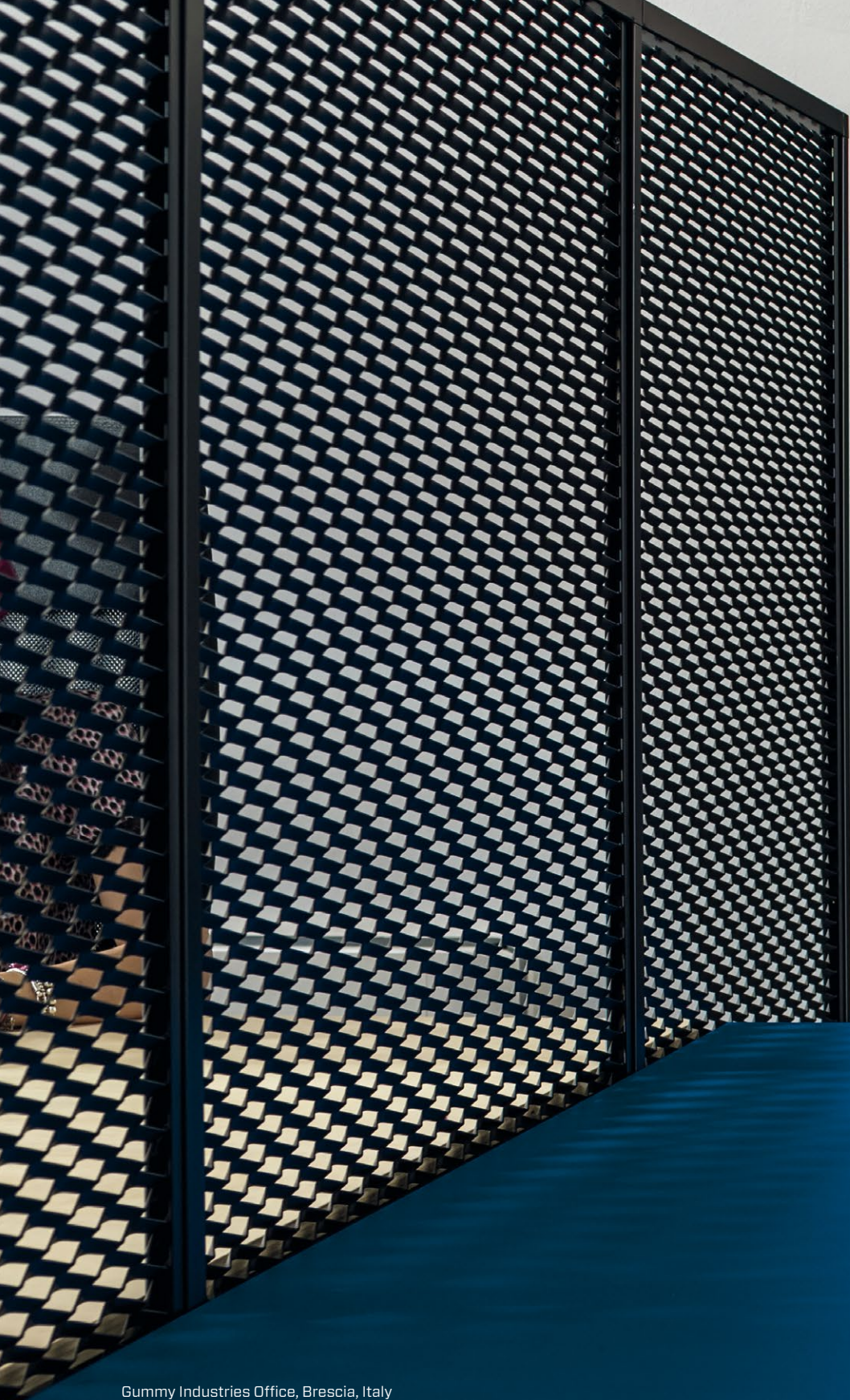



RAFFLES MILANO.IT

10 BUONI MOTIVI PER SCEGLIERE RAFFLES MILANO ISTITUTO MODA E DESIGN

- 1 UN AMBIENTE INTERNAZIONALE
- 2 UNA FACILITY DI PRESTIGIO
- 3 NUMERO CHIUSO
- 4 UNA SCUOLA SEMPRE APERTA
- 5 UNA VISIONE TRANS-DISCIPLINARE
- 6 STUDIO E DESIGN
- 7 ESPERIENZE ALTERNATIVE
- 8 MONDAY TALKS
- 9 BIM CLUB
- 10 CAREER SERVICE

RafflesMilano Interior Design

Run

Dorino e Ferruccio Fantin, 1987



Run trolleys were created more than 30 years ago for work on the go. Thanks to their solid metal frames, they can carry loads of all kinds. Swivel castors make them easy to move around in complete safety. There is a choice between standard wheels with an industrial look and others featuring metal rims that are the same colour as the framework, which are better suited to household environments, both indoor and outdoor.

Los carros Run se crearon hace más de treinta años para los trabajos en movimiento. Gracias a la sólida estructura metálica, permiten transportar cualquier tipo de carga. La facilidad de movimiento con total seguridad está garantizada por las ruedas giratorias, las cuales están disponibles en la versión estándar, con una estética industrial, o con un disco metálico del mismo color que el marco, para una mayor adaptabilidad a los ambientes domésticos.

Les chariots Run ont été créés il y a plus de trente ans pour les travaux itinérants. Grâce à leur structure métallique solide, ils permettent de transporter n'importe quelle charge. Les roulettes pivotantes permettent de les déplacer facilement et en toute sécurité. Celles-ci sont disponibles en version standard, avec un look industriel, ou avec des jantes métalliques de la même couleur que le cadre, mieux adaptées à l'environnement domestique.

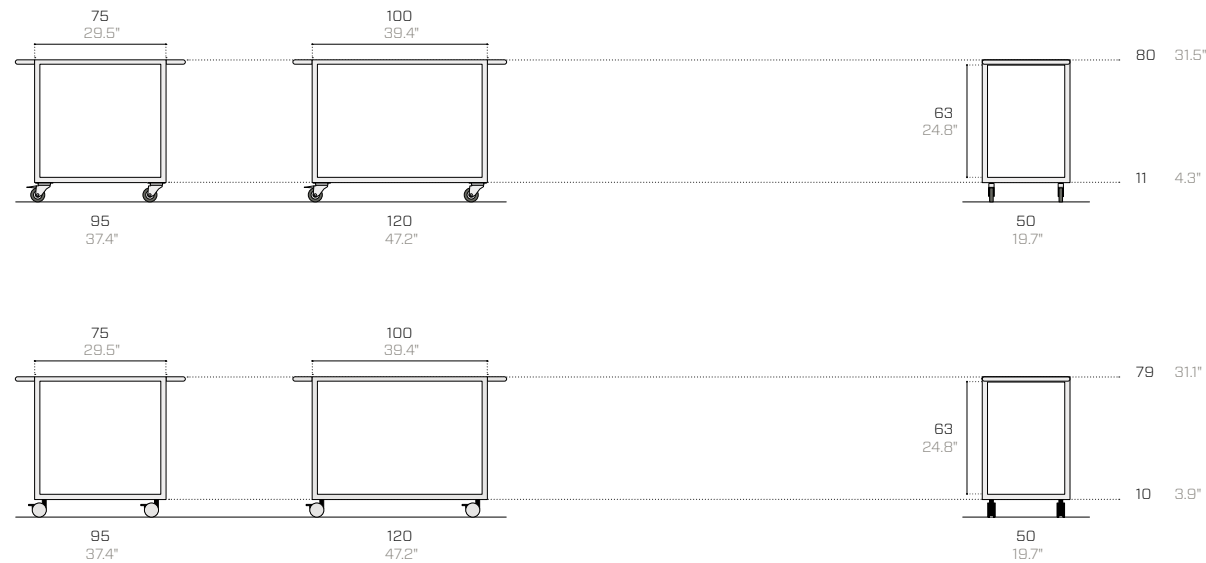

Mya

Sandro Fantin, 2019



Mya is a drawer unit on castors that slides silently, thanks to the top-quality materials and to the use of the best ball bearing runners. Designed to minimise the external dimensions – while providing the same drawer storage capacity – it has distinctive, practical inset handles with a diameter of 4 cm.

Mya es una cajonera rodante y silenciosa, gracias a la calidad de los materiales y al uso de las mejores guías de bolas. Diseñada para minimizar las dimensiones externas – con la misma capacidad de almacenamiento de los cajones – se caracteriza por la práctica manija empotrada de 4 cm de diámetro.

Mya est un caisson à tiroirs sur roulettes au coulissement silencieux, grâce à la qualité des matériaux et à l'utilisation des meilleures glissières à billes. Conçu pour minimiser les dimensions extérieures – avec la même capacité de rangement des tiroirs – il se caractérise par la pratique poignée intégrée de 4 cm de diamètre.

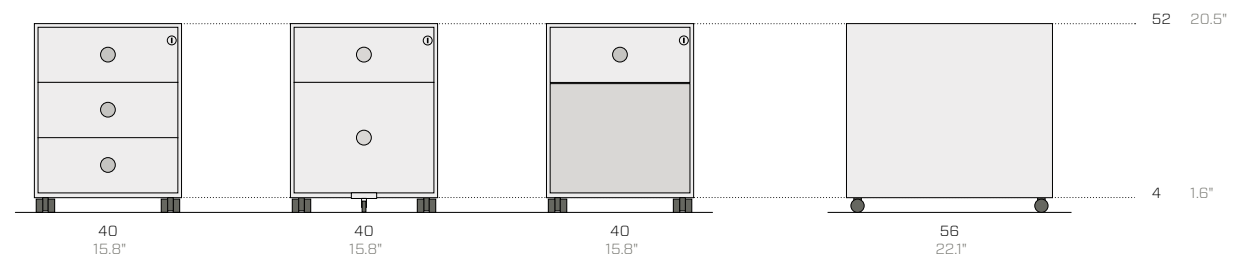

Classic

Dorino e Ferruccio Fantin, 1980-2020



The Classic collection is a timeless success, thanks to its sturdiness and well-proportioned shapes. It is available in a variety of sizes, with hinged or sliding doors, and it is suitable both for office archiving as well as for use as alternative storage for shops and the home. As in all the products in its collections, Fantin guarantees ease of assembly and ample colour customisation possibilities.

Classic es una colección con un éxito atemporal, gracias a la robustez y a las proporciones de las formas. Disponible en diferentes tamaños, con puertas batientes o correderas, es adecuado tanto para archivar en la oficina como para otras soluciones en tiendas y en el hogar. Como en todos los productos de sus colecciones, Fantin garantiza la facilidad de montaje y una amplia personalización del color.

Classic est une collection au succès intemporel, grâce à sa robustesse et à ses formes bien proportionnées. Proposée en différentes tailles, avec portes battantes ou coulissantes, elle convient aussi bien pour le classement au bureau que pour d'autres solutions de rangement dans les magasins et à la maison. Comme pour tous les produits de ses collections, Fantin garantit une facilité de montage et de nombreuses possibilités de personnalisation des couleurs.





Cabinets with hinged doors / Armarios con puertas batientes / Armoires avec portes battantes



Cabinets with sliding doors / Armarios con puertas correderas / Armoires avec portes coulissantes

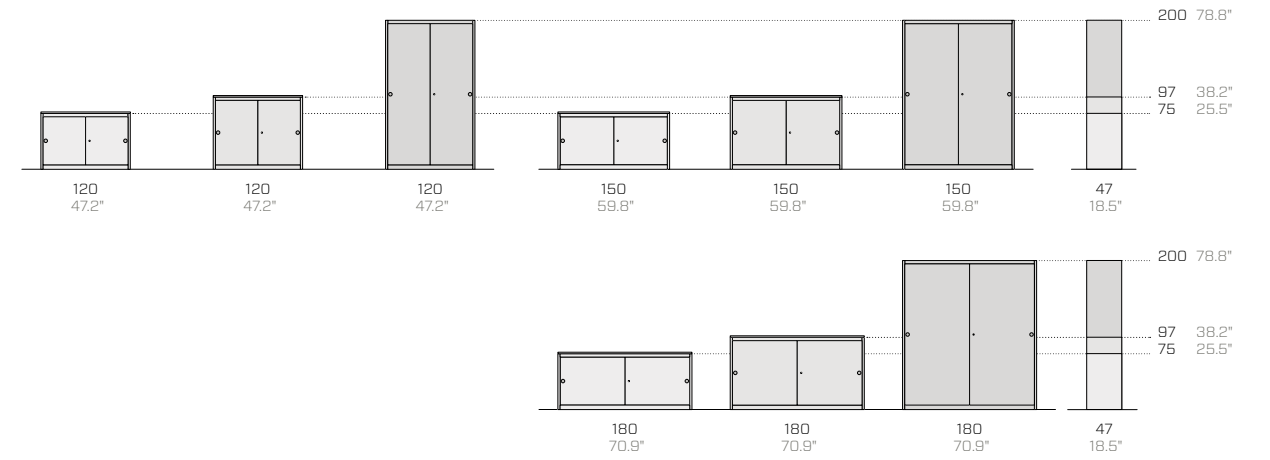

Cabinets with sliding tempered glass doors / Armarios con puertas correderas en vidrio templado / Armoires avec portes coulissantes en verre trempé

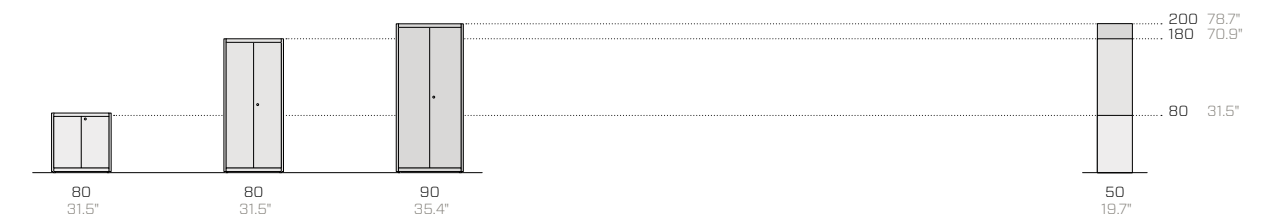

Essenza

Sandro Fantin, 2006

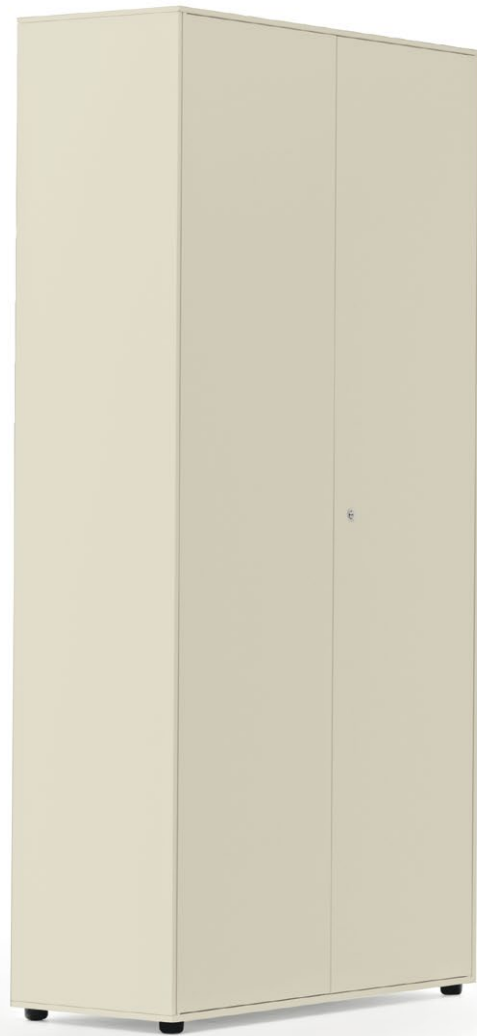

The Essenza collection has a slim thickness and minimal silhouettes refined down to the smallest detail, to accommodate the needs of the most demanding customers. The strength of metal guarantees solidity and durability, while a broad range of colours make for a versatile adaptation to the most sophisticated environments. The broad choice of internal accessories means all sorts of contents can be archived, while the use of just eight screws confirms that it is exceptionally easy to assemble, while nonetheless guaranteeing reliability over time, a feature, which distinguishes all Fantin products.

La colección Essenza tiene espesores finos y líneas minimalistas acabadas en detalle, para satisfacer las necesidades más exigentes. La fuerza del metal garantiza solidez y durabilidad, mientras que una amplia gama de colores permite una adaptación versátil en los ambientes más refinados. La amplia gama de accesorios internos permite archivar correctamente cualquier tipo de contenido, mientras que el uso de solo ocho tornillos confirma la facilidad de un montaje excepcional, garantizando al mismo tiempo esa fiabilidad en el tiempo que caracteriza no solo a Essenza, sino a todos los productos Fantin.

La collection Essenza présente de faibles épaisseurs et des lignes minimalistes aux finitions impeccables, pour répondre aux exigences les plus pointues. La résistance du métal est un gage de solidité et de longévité, tandis que la généreuse palette de couleurs permet une adaptation polyvalente dans les contextes les plus raffinés. La large gamme d'accessoires internes vous permet de classer correctement tout votre matériel. Par ailleurs, l'utilisation de seulement huit vis confirme une facilité de montage exceptionnelle, tout en garantissant la fiabilité dans le temps, une caractéristique qui distingue tous les produits Fantin.

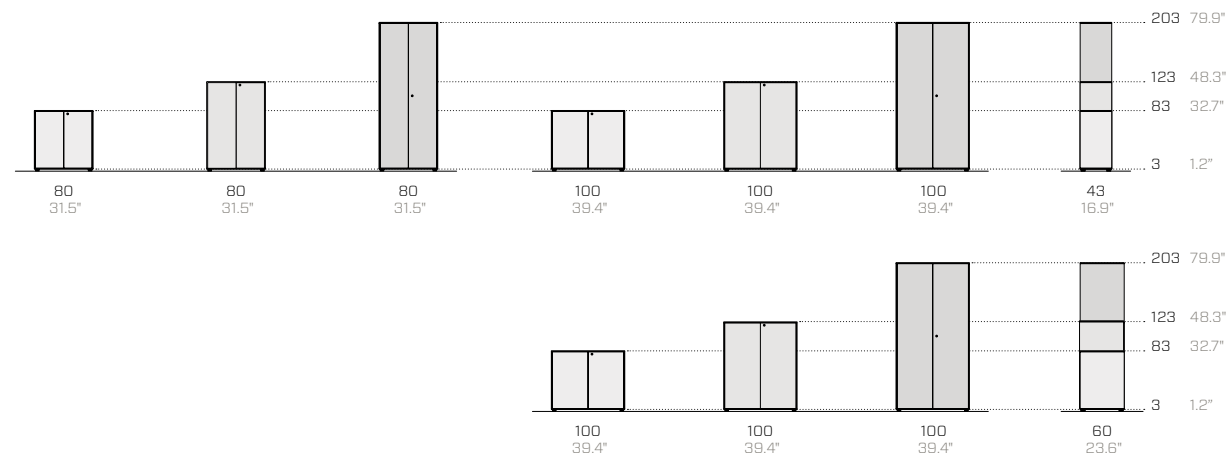

51.18

Sand / Arena / Sable

Embossed / Gofrado / Gaufré



Binaria

Salvatore Indriolo, 2013



The sophisticated shapes and painstaking care for technical details make Binaria the ideal solution for both public and private environments, even for new and unusual uses. The ergonomic recessed groove handle on the modules, which is achieved by removing some of the material from the décor panel, is the characteristic styling detail which sets out this system from the other collections available on the market today. In the version with the upright frame, Binaria truly becomes a small interior architecture, which plays the starring role of its setting.

Las formas refinadas y el cuidado de los detalles técnicos hacen de Binaria una solución apta tanto para ambientes públicos como privados, incluso para usos nuevos e inusuales. La manija ergonómica de los módulos, creada eliminando volúmenes, es la característica estética que diferencia a este sistema de las otras colecciones disponibles en el mercado hoy en día. En la versión con puente, Binaria se convierte en una pequeña arquitectura de interiores, protagonista en el centro de la escena.

Le raffinement des formes et l'attention portée aux détails techniques font de Binaria une solution adaptée aux espaces publics et privés, même pour des utilisations inédites et inhabituelles. La poignée rainure ergonomique des modules, résultat d'un évidement dans la façade, est le détail de style caractéristique qui démarque ce système des autres collections actuellement sur le marché. Dans la version avec pont, Binaria joue les vedettes et se transforme en véritable petite architecture d'intérieur.

Static module depths
Profundidad de módulos fijos
Profondeur des modules fixes
 30 cm
 11.8"

Sliding module depths
Profundidad de módulos móviles
Profondeur des modules mobiles
 60 cm
 23.6"

Module heights
Altura de módulos
Hauteurs des modules
 214 / 254 cm
 84.3" / 100"

Passage length
Longitud del pasillo
Longueur d'allée
 80 / 100 / 120 cm
 31.5" / 39.4" / 47.2"

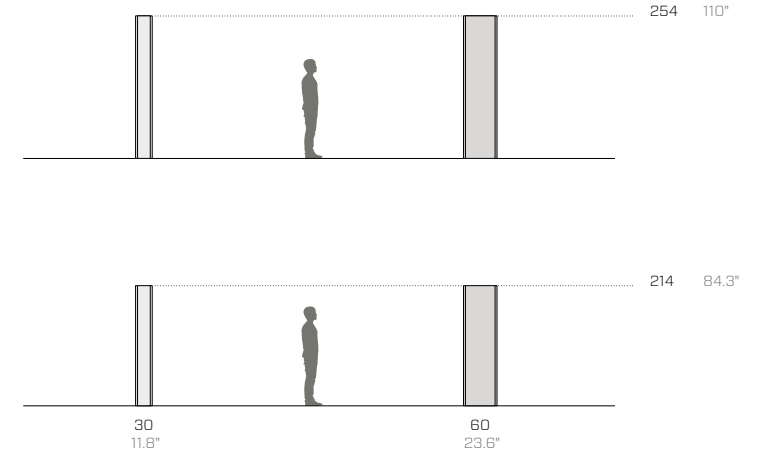

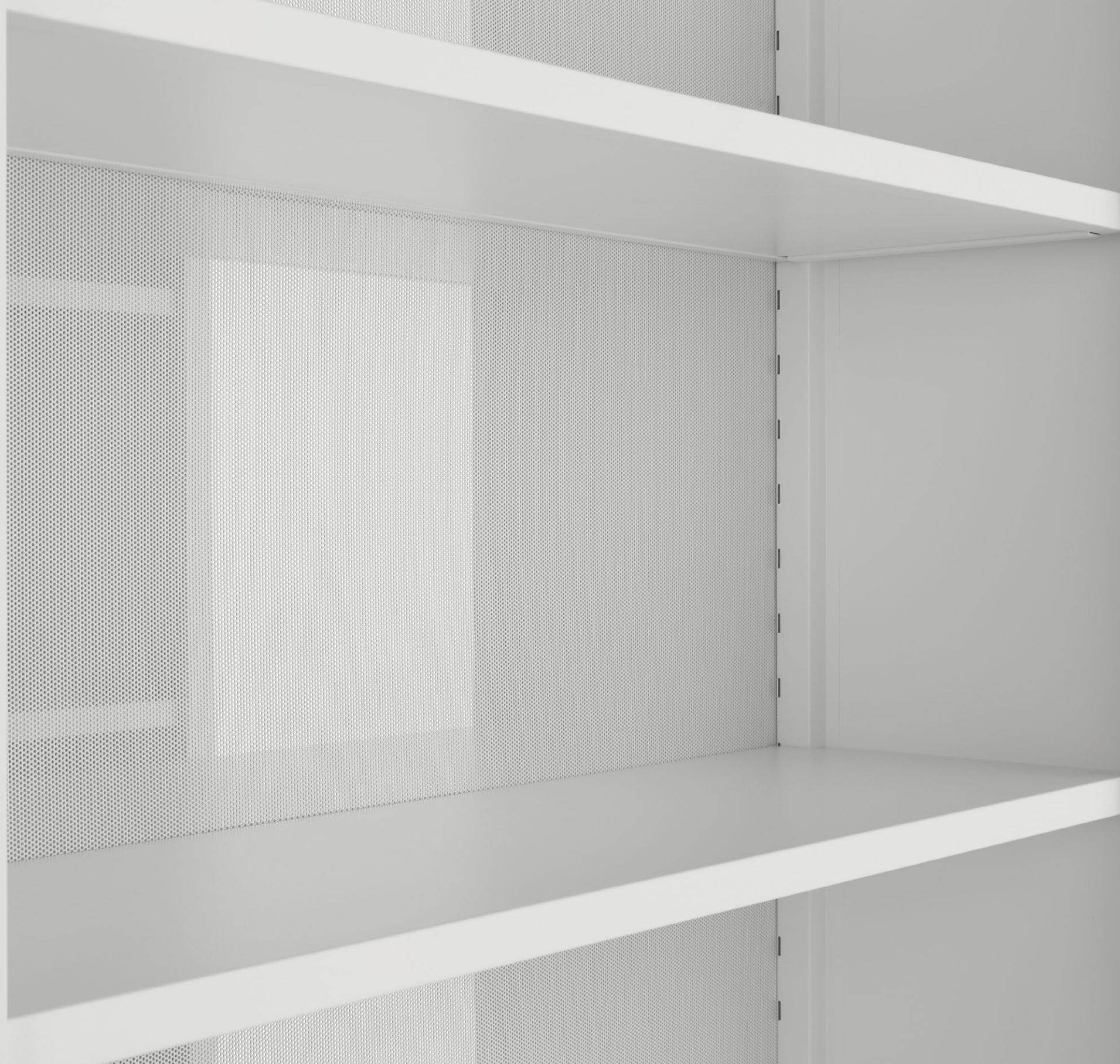

Great attention to detail is shown both outside and inside Fantin compactable wardrobes. This photo shows how the micro-perforated backboards add lightness to the appearance of the whole system. The height of the shelves can be adjusted at 5 cm (2") intervals, for maximum personalization of every module. New design solutions can also be proposed to cater to specific storage needs.

Los armarios compactos Fantin están cuidados en el más mínimo detalle, también internamente. En esta foto, se puede apreciar el uso de fondos microperforados, los cuales otorgan ligereza visual a todo el sistema. Los estantes, regulables en altura a intervalo de 5 cm (2"), garantizan la máxima personalización de cada módulo. Representan, además, nuevas soluciones de diseño para necesidades específicas de almacenamiento.

Les armoires mobiles Fantin sont soignées dans les moindres détails, à l'extérieur comme à l'intérieur. Cette photo montre comment les panneaux arrière microperforés ajoutent de la légèreté à l'ensemble du système. Les tablettes, réglables en hauteur au pas de 5 cm (2"), assurent le maximum de personnalisation à chaque module. De nouvelles solutions de conception peuvent également être proposées pour répondre à des besoins de rangement particuliers.



Vela

Salvatore Indriolo, 2013



Vela is distinguished by practical full-height handles, which mark the rhythm of the modules. The fundamental and ergonomic design of this model make it ideal for use in offices and professional practices, adding a touch of class to its surroundings. It can be installed free-standing, for free access from either side of the module, while at the same time turning into a practical partition for open-plan settings.

Vela se caracteriza por unas cómodas manijas que siguen toda la longitud de los módulos, marcando el ritmo de los mismos. Su esencialidad y ergonomía lo hacen ideal en oficinas y estudios profesionales, enalteciendo el ambiente en el que se coloca. Se puede posicionar de forma independiente, para tener un acceso libre desde ambos lados, convirtiéndose, al mismo tiempo, en un cómodo elemento divisorio de un open-space.

Vela se distingue par ses poignées pratiques sur toute la hauteur, qui marquent le rythme des modules. Son look épuré et son ergonomie en font une solution idéale pour les bureaux et les cabinets professionnels, ajoutant une touche de classe à son environnement. Elle peut être autoportante, pour permettre un accès libre des deux côtés tout en se transformant en une cloison de séparation pratique pour les espaces ouverts.

Static module depths
Profundidad de módulos fijos
Profondeur des modules fixes
30 cm
11.8"

Sliding module depths
Profundidad de módulos móviles
Profondeur des modules mobiles
60 cm
23.6"

Module heights
Altura de módulos
Hauteurs des modules
214 / 254 cm
84.3" / 100"

Passage length
Longitud del pasillo
Longueur d'allée
80 / 100 / 120 cm
31.5" / 39.4" / 47.2"

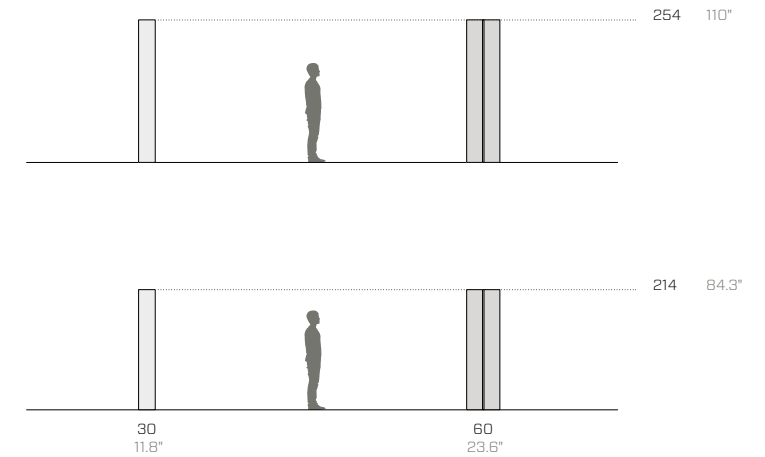





Discovery

Salvatore Indriolo, 2013



Discovery is the perfect solution for those who want both contemporary design and ample storage space. The pure and minimal silhouettes mean it blends in seamlessly not only in hidden environments, which is the case for the majority of these systems, but also when visible to clients in professional practices, top-end shops or other settings where appearance is all-important.

Discovery es ideal para quienes desean un diseño refinado y grandes espacios de almacenamiento al mismo tiempo. Las líneas puras y minimalistas permiten su colocación, no solo en ambientes ocultos, como ocurre con la mayoría de estos sistemas, sino también visibles en estudios profesionales, tiendas de alta gama u otras situaciones donde el aspecto de exhibición es importante.

Discovery est l'idéal pour ceux qui souhaitent à la fois un design raffiné et de grands volumes de rangement. Grâce à ses lignes épurées et minimalistes, elle s'intègre parfaitement non seulement dans des espaces dissimulés, comme c'est le cas pour la plupart de ces systèmes, mais aussi dans les cabinets professionnels, les magasins haut de gamme ou d'autres lieux où l'esthétique est importante.







Static module depths
Profundidad de módulos fijos
Profondeur des modules fixes
30 / 35 / 40 / 45 / 50 cm
11.8" / 13.8" / 15.7" / 17.7" / 19.7"

Sliding module depths
Profundidad de módulos móviles
Profondeur des modules mobiles
60 / 70 / 80 / 90 / 100 cm
23.6" / 27.6" / 31.5" / 35.4" / 39.4"

Module heights
Altura de módulos
Hauteurs des modules
218.5 / 228.5 / 258.5
288.5 / 303.5 cm
86" / 90" / 101.8"
113.6" / 119.5"

Passage length
Longitud del pasillo
Longueur d'allée
163 / 183 / 203 / 223 / 243
263 / 283 / 303 / 323 / 343
363 / 383 / 403 / 423 / 443
463 / 483 / 503 / 523 / 543
563 / 583 / 603 cm
64.2" / 72" / 79.9" / 87.8" / 95.7"
103.5" / 111.4" / 119.3" / 127.2"
135" / 142.9" / 150.8" / 158.7"
166.5" / 174.4" / 182.3" / 190.2"
198" / 205.9" / 213.8" / 221.7"
229.5" / 237.4"

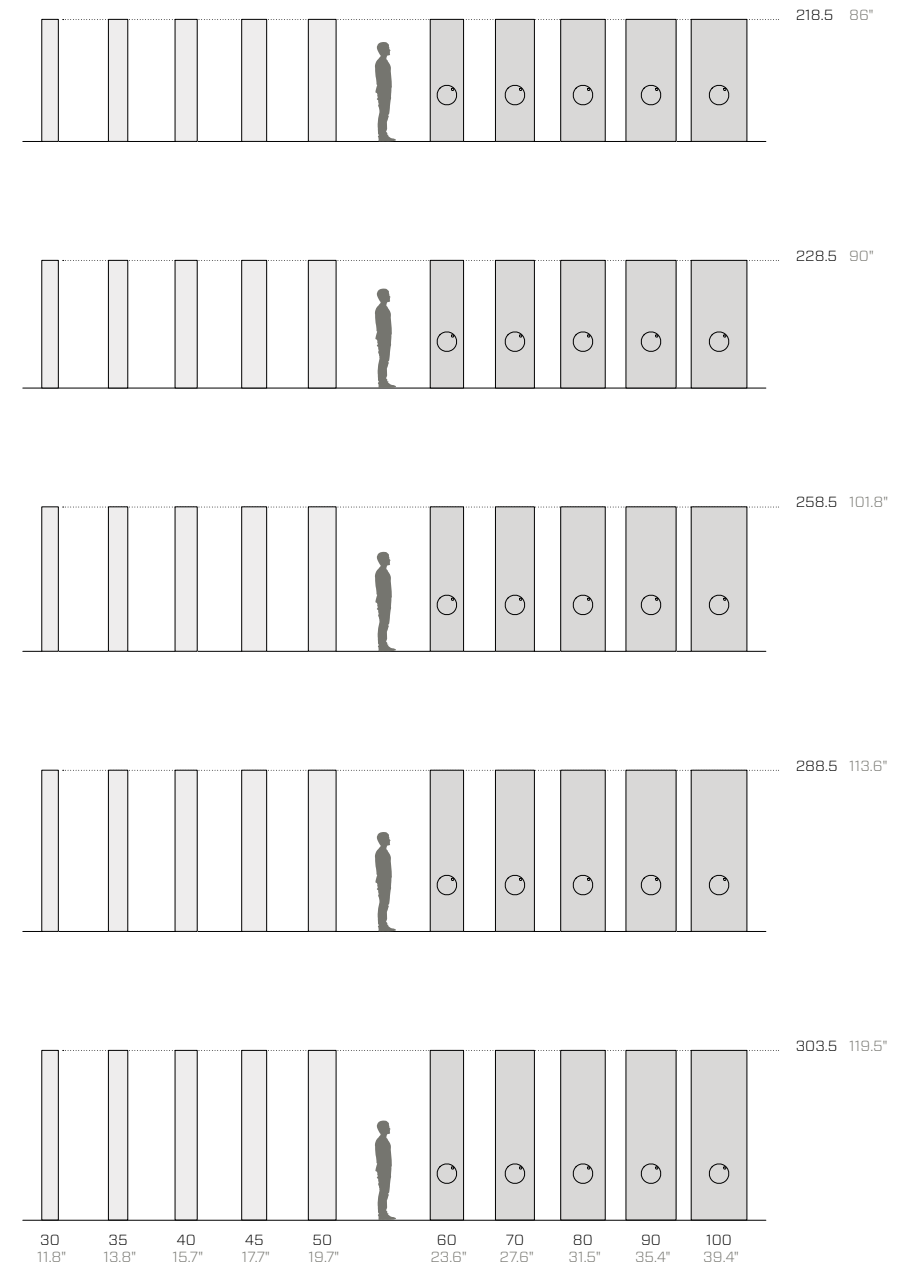



Ad hoc

7.

6.

1998 | 2008

1992 | 1997



1

The Archive

Da luogo statico, legato al passato, l'archivio si trasforma in un sistema multimediale in cui la classificazione storica, di oggetti e progetti, è affiancata da tecnologie digital e social di ultima generazione, dal tablet a Pinterest. In ciascuno dei 9 moduli-scaffale si sviluppa una timeline che parte dagli Anni 50 e arriva a oggi, ricostruendo con oggetti-capofila la storia degli arredi per ufficio: sistemi operativi, lampade, sedute, senza dimenticare la tecnologia, dalle calcolatrici ai computer. Una storia tutta da scoprire, e approfondire, nello storytelling delle bacheche di Pinterest e negli approfondimenti da sfogliare sui device.

1948 1960

Drawing from its static past, the archive transforms into a multimedia system, in which the historical classification of objects is paired with the latest generation of digital and social technologies: from tablets to Pinterest. A timeline within each of the nine shelving units takes you on journey, starting from the 1950s and culminating in the present-day, where the history of office design is reconstructed with iconic objects from the past: operating systems, lamps, chairs, and of course - technology: from calculators to computers. This is a story to discover and explore on Pinterest, by accessing Pinterest boards and by browsing on tablet.





Berengo Showroom, Venice, Italy



© Matteo Piazza

Ad hoc 226-227

Our Vision

A strong Vision supported by a value enhancing business model.

We are the leading platform where innovation, entrepreneurship and education coexist and create contamination: using a digital approach, we support the creation of new business models and the transformation and education of young people and companies. Founded in January 2005, we were the first in the world to adopt a model that combined investments, business consulting and digitally-driven educational programmes in one place.

Now we are a human - centered ecosystem based on a 3-pillar business model that combined together benefit from synergies and interconnections for value creation. Our Campus is an international hub where students and professionals collaborate together in the digital transformation process. Is a place for sharing ideas and a privileged point of view on the future, on new trends in the workplace, on technological advancements and on how the digital transformation will change society.

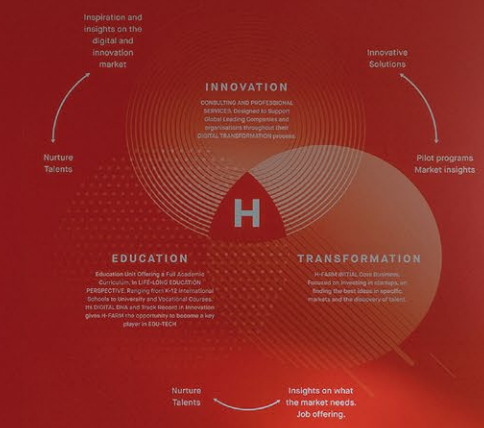

- Partners: CISCO, IBM, CATERPILLAR, GARRINET, SAP, DELL, HP, LG, PRIME, IOT, ASSA ABLOY, AXIS

Indoor finishes







Finishes for metal / Acabados para metal / Finitions pour le métal	Metal essentials	234
	Metal design	235
Finishes in other materials / Acabados en otros materiales / Finitions dans d'autres matériaux	Glass essentials	236
	Glass design	237
	Stainless steel / Acero inoxidable / Acier inoxydable	238
	Melamine coated / Melamina / Mélaminé	238
	Fabric / Tejido / Tissu	238
	Technical informations / Información técnica / Informations techniques	239

Metal essentials





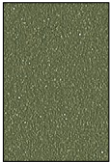

	01.18 Black (RAL 9005) Negro / Noir --- EM ▲		08.20 Rose quartz Rosa cuarzo / Quartz rose --- EM ▲■		15.19 Forest green (RAL 6007) Verde bosque / Verte forêt --- EM ▲●
	02.18 Anthracite (RAL 7021) Antracita / Anthracite --- EM ▲●■		09.24 Terracotta (RAL 8004) Terracota / Terre cuite --- EM ▲●■		16.24 Cement (RAL 7033) Cemento / Ciment --- EM ▲●■
	03.18 Fantin grey Fantin gris / Gris Fantin --- EM ▲●■		10.21 Flame red (RAL 3000) Rojo Fuego / Rouge feu --- EM ▲		17.24 Slate (RAL 7031) Pizarra / Ardoise --- EM ▲●■
	04.18 Light grey (RAL 7035) Gris claro / Gris clair --- EM ▲●■		11.21 Melon yellow (RAL 1028) Amarillo melón / Jaune melon --- EM ▲●		18.21 Dusty blue (RAL 5014) Azul polvoriento / Bleu poussiéreux --- EM ▲■
	05.19 Cloud grey Gris nube / Gris nuage --- EM ▲■		12.19 Zinc yellow (RAL 1018) Amarillo zinc / Jaune de zinc --- EM ▲■		19.18 Gentian blue (RAL 5010) Azul genciana / Bleu gentiane --- EM ▲●
	06.18 White (RAL 9016) Blanco / Blanc --- EM ▲■		13.21 Pastel green (RAL 6019) Verde pastel / Vert pastel --- EM ▲●■		20.19 Steel blue (RAL 5011) Azul acero / Bleu acier --- EM ▲
	07.21 Milk white (RAL 9001) Blanco leche / Blanc de lait --- EM ▲●■		14.18 Sage green (RAL 6021) Verde salvia / Vert sauge --- EM ▲●■		21.21 Coffee brown (RAL 8019) Marrón café / Marron café --- EM ▲■

Metal design

Metallic

	61.24 Pale gold Oro claro / Or clair --- EM ▲■
	62.24 Copper Cobre / Cuivre --- EM ▲●■
	47.21 Platinum Platino / Platine --- EM ▲
	43.21 Bronze Bronce / Bronze --- EM ▲
	63.24 Graphite Grafito / Graphite --- EM ▲●
	64.24 Silver green Verde plateado / Vert argenté --- EM ▲●
	65.24 Silver blue Azul plateado / Bleu argenté --- EM ▲●

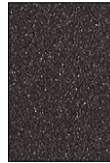
Earth

	51.18 Sand Arena / Sable --- EM ▲●
	57.21 Clay Creta / Crète --- EM ▲●
	52.18 Moss Musgo / Mousse --- EM ▲●
	66.24 Lichen Liquen / Lichen --- EM ▲■
	67.24 Pink clay Arcilla rosa / Argile rose --- EM ▲●■
	68.24 Sodalite Sodalita / Sodalite --- EM ▲
	56.21 Ocean Oceano / Océan --- EM ▲

Surfaces / Superficies / Surfaces

EM Embossed / Gofrado / Gaufré

Use / Usos / Utilisations

- ▲ Tops / Encimeras / Plans
- Outdoor / Exteriores / Extérieur
- Food / Alimentario / Alimentaire

Glass essentials

G01.23
Black (RAL 9005)
Negro / Noir

ET ▲ ■

G08.23
Rose quartz
Rosa cuarzo / Quartz rose

ET ▲ ■

G15.23
Forest green (RAL 6007)
Verde bosque / Verte forêt

ET ▲ ■

G02.23
Anthracite (RAL 7021)
Antracita / Anthracite

ET ▲ ■

G09.24
Terracotta (RAL 8004)
Terracota / Terre cuite

ET ▲ ■

G16.24
Cement (RAL 7033)
Cemento / Ciment

ET ▲ ■

G03.23
Fantini grey
Fantini gris / Gris Fantini

ET ▲ ■

G10.23
Flame red (RAL 3000)
Rojo Fuego / Rouge feu

ET ▲ ■

G17.24
Slate (RAL 7031)
Pizarra / Ardoise

ET ▲ ■

G04.23
Light grey (RAL 7035)
Gris claro / Gris clair

ET ▲ ■

G11.23
Melon yellow (RAL 1028)
Amarillo melón / Jaune melon

ET ▲ ■

G18.23
Dusty blue (RAL 5014)
Azul polvoriento / Bleu poussiéreux

ET ▲ ■

G05.23
Cloud grey
Gris nube / Gris nuage

ET ▲ ■

G12.23
Zinc yellow (RAL 1018)
Amarillo zinc / Jaune de zinc

ET ▲ ■

G19.23
Gentian blue (RAL 5010)
Azul genciana / Bleu gentiane

ET ▲ ■

G06.23
White (RAL 9016)
Blanco / Blanc

ET ▲ ■

G13.23
Pastel green (RAL 6019)
Verde pastel / Vert pastel

ET ▲ ■

G20.23
Steel blue (RAL 5011)
Azul acero / Bleu acier

ET ▲ ■

G07.23
Milk white (RAL 9001)
Blanco leche / Blanc de lait

ET ▲ ■

G14.23
Sage green (RAL 6021)
Verde salvia / Vert sauge

ET ▲ ■

G21.23
Coffee brown (RAL 8019)
Marrón café / Marron café

ET ▲ ■

Glass design

G61.24
Pale gold
Oro claro / Or clair

ET ▲ ■

G51.23
Sand
Arena / Sable

ET ▲ ■

G62.24
Copper
Cobre / Cuivre

ET ▲ ■

G57.23
Clay
Creta / Crète

ET ▲ ■

G47.23
Platinum
Platino / Platine

ET ▲ ■

G52.23
Moss
Musgo / Mousse

ET ▲ ■

G43.23
Bronze
Bronce / Bronze

ET ▲ ■

G66.24
Lichen
Liquen / Lichen

ET ▲ ■

G63.24
Graphite
Grafito / Graphite

ET ▲ ■

G67.24
Pink clay
Arcilla rosa / Argile rose

ET ▲ ■

G64.24
Silver green
Verde plateado / Vert argenté

ET ▲ ■

G68.24
Sodalite
Sodalita / Sodalite

ET ▲ ■

G65.24
Silver blue
Azul plateado / Bleu argenté

ET ▲ ■

G56.23
Ocean
Oceano / Océan

ET ▲ ■

Surfaces / Superficies / Surfaces

ET Etched / Mateado / Gravé

Use / Usos / Utilisations

- ▲ Tops / Encimeras / Plans
- Outdoor / Exteriores / Extérieur
- Food / Alimentario / Alimentaire

Stainless steel
Acero inoxidable
Acier inoxydable

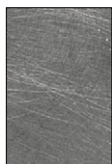

K1.18
Inox Vintage
Inox Vintage / Inox Vintage

HG ▲ ● ■



K2.19
Inox Satin
Inox satin / Inox satin

HG ▲ ● ■

Melamine coated
Melamina
Méla miné



M3.21
Black
Negro / Noir

EM ▲

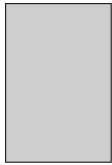

M1.18
Grey
Gris / Gris

EM ▲



M2.18
White
Blanco / Blanc

EM ▲



M4.18
Natural oak
Roble natural / Chêne naturel

EM ▲

Fabric
Tejido
Tissu



T1.22
Smoke
Humo / Fumée

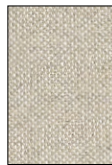

T2.22
Hemp
Cáñamo / Chanvre



T3.22
Cherry
Cereza / Cerise



T4.22
Amber
Ámbar / Ambre



T5.22
Leaf
Hoja / Feuille



T6.22
Denim
Denim / Denim



T7.22
Taupe
Tórtola / Tourterelle

Surfaces / Superficies / Surfaces

EM Embossed / Gofrado / Gaufré
MT Matt / Mate / Mat
HG High Gloss / Alto brillo / Haute brillance

Use / Usos / Utilisations

▲ Tops / Encimeras / Plans
● Outdoor / Exteriores / Extérieur
■ Food / Alimentario / Alimentaire

Technical information

Metal Non-toxic powder coating for interior use, with no heavy metals. Cured in an oven at 190 °C, following degreasing and phosphating. Guaranteed minimum thickness of 50 microns. Minimum resistance to salt spray of 200 hours (in accordance with the ASTM B117 standard). Some finishes are suitable for direct contact with food as required by Italian Law Decree D.M. 21/03/73 and subsequent updates. Requests for other RAL finishes can be considered. On some finishes, any partial discolouration following rubbing and/or abrasion has absolutely no effect on the technical, appearance/colour and chemical/physical characteristics of the product. This phenomenon tends to diminish over the useful life of the product and does not in any case present a health hazard to users.

Glass Extra-clear glass, with a thickness of 6 mm (0.24"), etched on the top, ground with a matt edge. Coated on the back with water-based paint in the 35 Fantin finishes.

AISI 304 stainless steel Kitchen top with a thickness of 4 mm (0.16") with Vintage (exclusive Barazza manual processing, making it quicker and easier to maintain) or satin finish.

Melamine coated Faced top with a fibre-board structure and a coloured or wood-effect melamine finish. Requests for other melamine finishes will be considered.

Fabric Made from GRS-certified 100% recycled yarn. Composition: 75% cotton, 20% acrylic, 5% other fibres. Weight: 328 g/m2.

Información técnica

Metal Recubrimiento en polvo atóxico para interiores, sin metales pesados, con paso en horno a 190 °C, previo tratamiento de desengrase y fosfatación. Espesor mínimo garantizado 50 micrones, resistencia mínima en niebla salina igual a 200 horas (norma ASTM B117). Algunos acabados son aptos para el contacto directo con alimentos, según lo previsto por el decreto italiano D.M. 21/03/73 y posteriores actualizaciones. Se pueden evaluar otros acabados RAL bajo pedido.

En algunos acabados, una decoloración parcial debida al roce y/o a la abrasión no afecta en absoluto a las características técnicas, de aspecto/color y químicas/físicas del producto. Este fenómeno tiende a disminuir a lo largo de la vida útil del producto y no representa en ningún caso un peligro para la salud de los usuarios.

Vidrio Vidrio extraclaro de 6 mm (0.24") de espesor, mateado al ácido en la parte superior, esmerilado con borde opaco. Pintado en la parte trasera con pintura al agua en los 35 acabados Fantin.

Acero inoxidable AISI 304 Encimera de cocina de 4 mm de espesor (0.16") con acabado vintage (producción manual exclusiva Barazza, cuyo mantenimiento es más simple y fácil) o satinado.

Melamina Superficie en melamina con estructura en panel de fibras de madera, revestido con acabados melamínicos de color o efecto madera. Se pueden evaluar otros acabados melamínicos bajo pedido.

Tejido Hecho con hilos 100 % regenerados, certificado GRS. Composición: 75% algodón, 20 % acrílico, 5 % otras fibras. Peso: 328 g/m2.

Informations techniques

Métal Revêtement en poudre non toxique pour l'intérieur sans métaux lourds, avec passage au four à 190 °C, après traitement de dégraissage et de phosphatation. Épaisseur minimale garantie de 50 microns. Résistance minimale au brouillard salin de 200 heures (norme ASTM B117). Certaines finitions sont adaptées au contact direct avec les aliments, comme l'exige l'arrêté ministériel italien du 21/03/73 et ses mises à jour ultérieures. Autres finitions RAL possibles sur demande.

Sur certaines finitions, une éventuelle décoloration partielle due au frottement et/ou à l'abrasion n'a absolument aucune incidence sur les caractéristiques techniques, d'aspect/couleur et chimiques/physiques du produit. Ce phénomène tend à s'atténuer au cours de la vie utile du produit et ne présente en aucun cas un danger pour la santé des utilisateurs.

Verre Verre extra-clair de 6 mm (0.24") d'épaisseur, décapé sur la face supérieure, bord meulé mat. Rétro-laqué avec peinture à l'eau dans les 35 finitions Fantin.

Acier inoxydable AISI 304 Plan de travail de cuisine de 4 mm (0.16") d'épaisseur avec finition Vintage (traitement manuel exclusif Barazza, pour un entretien plus facile et plus pratique) ou satinée.









Méla miné Plateau en mélaminé, constitué d'un panneau de fibres de bois avec finition en mélamines colorées ou à effet bois. Autres finitions en mélamines possibles sur demande.

Tissu Obtenu à partir de fils 100 % régénérés, certifiés GRS. Composition : 75 % coton, 20 % acrylique, 5 % autres fibres. Poids 328 g/m2.

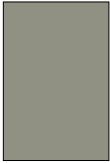
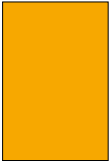
Outdoor finishes

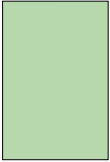

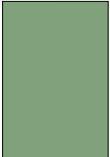

Finishes for metal / Acabados para metal / Finitions pour le métal	Metal essentials	242
	Metal design	243
Finishes in other materials / Acabados en otros materiales / Finitions dans d'autres matériaux	Stainless steel / Acero inoxidable / Acier inoxydable	244
	Technical informations / Información técnica / Informations techniques	245

Metal essentials



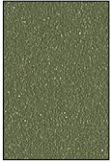

	02.18 Anthracite (RAL 7021) Antracita / Anthracite --- EM ▲●■		09.24 Terracotta (RAL 8004) Terracota / Terre cuite --- EM ▲●■		15.19 Forest green (RAL 6007) Verde bosque / Verte forêt --- EM ▲●
	03.18 Fantin grey Fantin gris / Gris Fantin --- EM ▲●■		11.21 Melon yellow (RAL 1028) Amarillo melón / Jaune melon --- EM ▲●		16.24 Cement (RAL 7033) Cemento / Ciment --- EM ▲●■
	04.18 Light grey (RAL 7035) Gris claro / Gris clair --- EM ▲●■		13.21 Pastel green (RAL 6019) Verde pastel / Vert pastel --- EM ▲●■		17.24 Slate (RAL 7031) Pizarra / Ardoise --- EM ▲●■
	07.21 Milk white (RAL 9001) Blanco leche / Blanc de lait --- EM ▲●■		14.18 Sage green (RAL 6021) Verde salvia / Vert sauge --- EM ▲●■		19.18 Gentian blue (RAL 5010) Azul genciana / Bleu gentiane --- EM ▲●

Metal design

Metallic

	62.24 Copper Cobre / Cuivre --- EM ▲●■
	63.24 Graphite Grafito / Graphite --- EM ▲●
	64.24 Silver green Verde plata / Vert argent --- EM ▲●
	65.24 Silver blue Azul plata / Blue argent --- EM ▲●

Earth

	51.18 Sand Arena / Sable --- EM ▲●
	57.21 Clay Creta / Crête --- EM ▲●
	52.18 Moss Musgo / Mousse --- EM ▲●
	67.24 Pink clay Arcilla rosa / Argile rose --- EM ▲●■

All Fantin outdoor products should be placed under a shelter, protected from atmospheric agents. It is advisable to clean the surfaces regularly according to the instructions for use and maintenance.

I prodotti Fantin outdoor devono essere collocati sotto una copertura, al riparo dall'esposizione diretta agli agenti atmosferici. Si consiglia di pulire regolarmente le superfici, seguendo le prescrizioni di uso e manutenzione.

Alle Outdoor Fantin-Produkte müssen vor Witterungseinflüssen unter einem Schutzdach aufzustellen. Es ist ratsam, die Oberflächen regelmäßig unter Beachtung der Gebrauchs- und Wartungsanweisungen zu reinigen.

Surfaces / Superficies / Surfaces

EM Embossed / Gofrado / Gaufré

Use / Usos / Utilisations

- ▲ Tops / Encimeras / Plans
- Outdoor / Exteriores / Extérieur
- Food / Alimentario / Alimentaire

Stainless steel
Acero inoxidable
Acier inoxydable

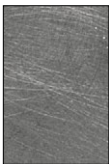

K1.18
Inox Vintage
Inox Vintage / Inox Vintage
- - -
HG ▲ ● ■



K2.19
Inox Satin
Inox satinado / Inox satiné
- - -
HG ▲ ● ■

Surfaces / Superficies / Surfaces



HG
High Gloss / Alto brillo / Haute brillance



Surfaces / Superficies / Surfaces

HG High Gloss / Alto brillo / Haute brillance

Use / Usos / Utilisations

- ▲ Tops / Encimeras / Plans
- Outdoor / Exteriores / Extérieur
- Food / Alimentario / Alimentaire

Technical information

All Fantin outdoor products must be kept under a shelter and protected from direct exposure to the elements. The surfaces should be cleaned and dried on a regular basis, in accordance with the use and maintenance instructions (see the warranty details in point 7 of the terms and conditions of sale).

Metal Non-toxic powder coating for interior use, with no heavy metals. Cured in an oven at 190°C, following degreasing and phosphating. Guaranteed minimum thickness of 50 microns. Minimum resistance to salt spray of 200 hours (in accordance with the ASTM B117 standard). Some finishes are suitable for direct contact with food as required by Italian Law Decree D.M. 21/03/73 and subsequent updates. Before the coating is added, it is possible to give the products a special treatment to make them more resistant to wear and exposure to the elements. Requests for other RAL finishes can be considered.

On some finishes, any partial discolouration following rubbing and/or abrasion has absolutely no effect on the technical, appearance/colour and chemical/physical characteristics of the product. This phenomenon tends to diminish over the useful life of the product and does not in any case present a health hazard to users.

AISI 304 stainless steel Kitchen top with a thickness of 4 mm (0.16"), with Vintage (exclusive Barazza manual processing, making it quicker and easier to maintain) or satin finish.

AISI 316 stainless steel Steel top with 6 mm (0.24") slim edge, made with an aluminium honeycomb support, available in Vintage (exclusive Barazza manual processing, making it quicker and easier to maintain) or satin finish. AISI 316 stainless steel – a material suitable for outdoor use – provides better resistance in environments where saltiness is present, particularly in seaside areas. It is also resistant to the corrosive effects of chlorine and particularly aggressive detergents.

Información técnica

Los artículos de exteriores del catálogo Fantin deben ser colocados bajo una cubierta, protegido de la exposición directa a los agentes atmosféricos. Se recomienda limpiar y secar las superficies periódicamente, siguiendo las instrucciones de uso y mantenimiento (ver la garantía en el art. 7 de las condiciones de venta).

Metal Recubrimiento en polvo atóxico para interiores, sin metales pesados, con paso en horno a 190°C, previo tratamiento de desengrase y fosfatación. Espesor mínimo garantizado 50 micrones, resistencia mínima en niebla salina igual a 200 horas (norma ASTM B117). Algunos acabados son aptos para el contacto directo con alimentos, según lo previsto por el decreto italiano D.M. 21/03/73 y posteriores actualizaciones. Antes de pintar, es posible evaluar la aplicación de un tratamiento para que los productos sean más resistentes al uso y a la exposición a los agentes atmosféricos. Tal tratamiento requiere un incremento en el precio. Se pueden evaluar otros acabados RAL bajo pedido.

En algunos acabados, una decoloración parcial debida al roce y/o a la abrasión no afecta en absoluto a las características técnicas, de aspecto/color y químicas/físicas del producto. Este fenómeno tiende a disminuir a lo largo de la vida útil del producto y no representa en ningún caso un peligro para la salud de los usuarios.

Acero inoxidable AISI 304 Encimera de cocina de 4 mm de espesor (0.16") con acabado vintage (producción manual exclusiva Barazza, cuyo mantenimiento es más simple y fácil) o satinado.

Acero inoxidable AISI 316 Encimera de cocina en acero con borde fino de 6 mm (0.24"), fabricada con un soporte con estructura de panal en aluminio; disponible en acabado vintage (producción manual exclusiva Barazza, cuyo mantenimiento es más simple y fácil) o satinado. El acero inoxidable AISI 316, material apto para ambientes exteriores, garantiza una mejor resistencia en ambientes con salinidad, especialmente en zonas marinas. También es resistente a los efectos corrosivos del cloro y a los detergentes particularmente agresivos.

Informations techniques

Les articles pour l'extérieur figurant dans le catalogue Fantin doivent être placés sous abri et protégés de l'exposition directe aux éléments. Il est recommandé de nettoyer et essuyer les surfaces régulièrement tel qu'indiqué dans les instructions d'utilisation et d'entretien (voir la garantie à l'art. 7 des conditions générales de vente).

Métal Revêtement en poudre non toxique pour l'intérieur sans métaux lourds, avec passage au four à 190°C, après traitement de dégraissage et de phosphatation. Épaisseur minimale garantie de 50 microns. Résistance minimale au brouillard salin de 200 heures (norme ASTM B117). Certaines finitions sont adaptées au contact direct avec les aliments, comme l'exige l'arrêté ministériel italien du 21/03/73 et ses mises à jour ultérieures. Avant la mise en peinture, il est possible de considérer l'application d'un traitement afin de rendre les produits plus résistants à l'usure et à l'exposition aux agents atmosphériques. Ce traitement fait l'objet d'un supplément. Autres finitions RAL possibles sur demande.

Sur certaines finitions, une éventuelle décoloration partielle due au frottement et/ou à l'abrasion n'a absolument aucune incidence sur les caractéristiques techniques, d'aspect/couleur et chimiques/physiques du produit. Ce phénomène tend à s'atténuer au cours de la vie utile du produit et ne présente en aucun cas un danger pour la santé des utilisateurs.

Acier inoxydable AISI 304 Plan de travail de cuisine de 4 mm (0.16") d'épaisseur avec finition Vintage (traitement manuel exclusif Barazza, pour un entretien plus facile et plus pratique) ou satinée.

Acier inoxydable AISI 316 Plan de travail avec bord Slim de 6 mm (0.24"), réalisé avec un panneau alvéolaire en aluminium, proposé en finition Vintage (traitement manuel exclusif Barazza, pour un entretien plus facile et plus pratique) ou satinée. L'acier inoxydable AISI 316 – matériau adapté aux espaces extérieurs – garantit une meilleure résistance dans les environnements salins, notamment en bord de mer. Il résiste également aux effets corrosifs du chlore et des produits d'entretien particulièrement agressifs.

Visual index / Índice visual / Index visuel



Frame
-
Bookcase
system
16



Frame
-
Tables
& desks
90



Uno living
142



Classic
182



Frame
-
Kitchens
& workbenches
32



Hug
-
Tables
& desks
98



Ali
146



Essenza
188

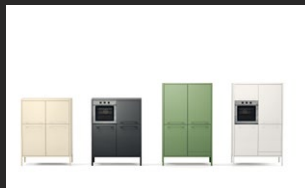

Frame
-
Tall units
52

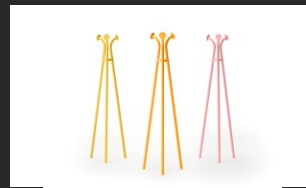

Hug
-
Hangers
110

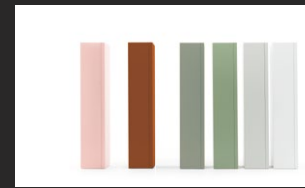

Just
154



Binaria
194

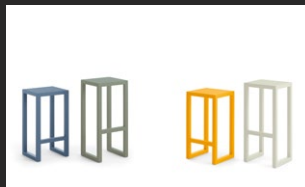

Frame
-
Stools
60

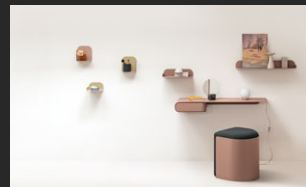

Wave
-
Desks
& add-ons
114



Cambio
162



Vela
202



Frame
-
Sideboards
& cupboards
66



Still
120

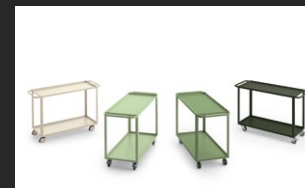

Run
174



Discovery
210



Frame
-
Beds
78



Uno
130

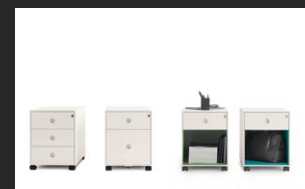

Mya
178

Thanks to our friends:
Gracias a nuestros amigos:
Merci à nos amis:

Billiani

Crassevig

Cucina 33

Dudubags

EligoStudio

FontanArte

Gervasoni

GT Design

Internoitaliano

Kristalia

LaCividina

Lapalma

Rina Menardi

Miniforms

Moroso

Oluce

Once Milano

Paola Paronetto

Twils

Hug hangers (2024)

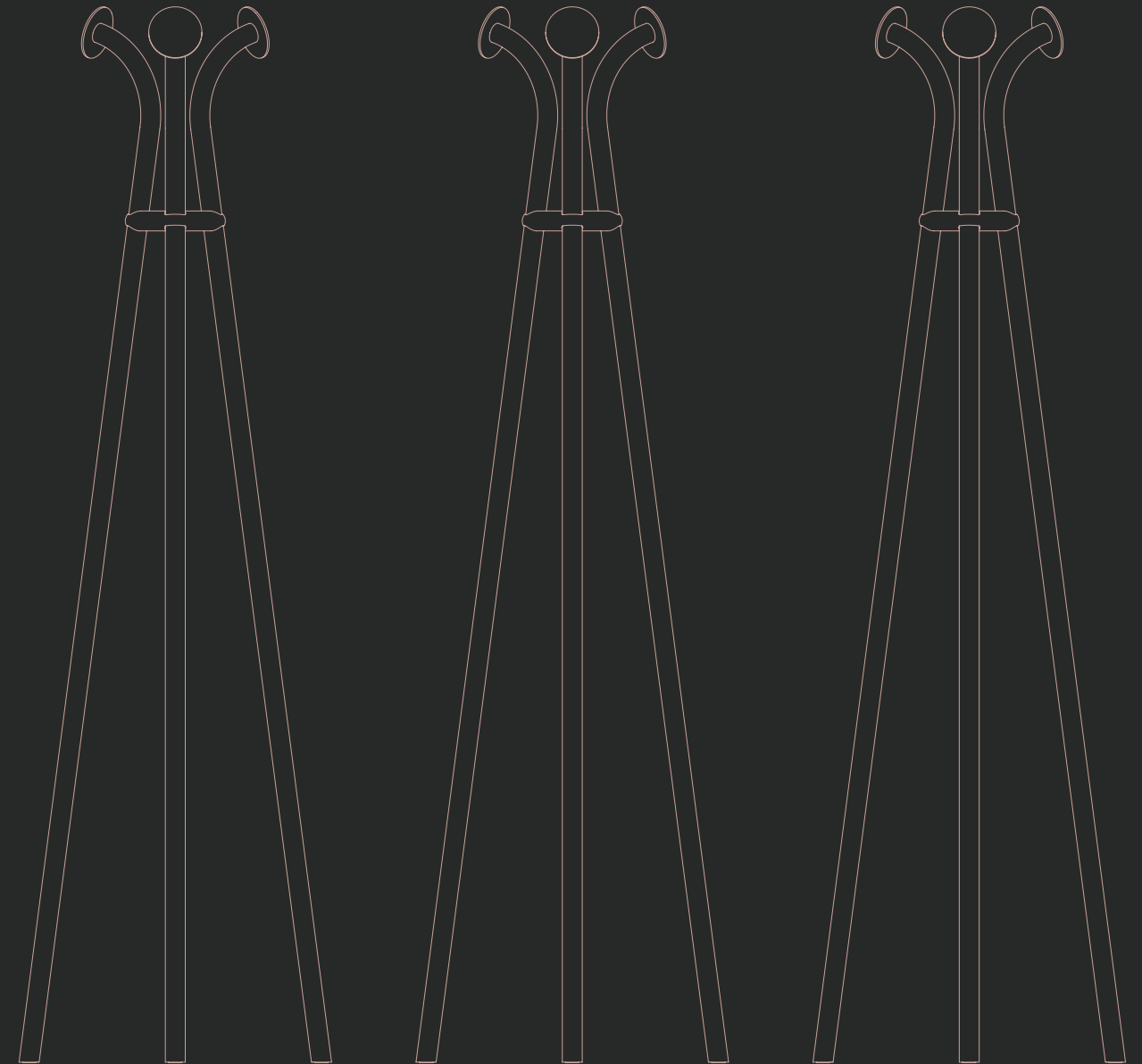

FANTIN

Catalogue 2024

Art direction

Salvatore Indriolo

Graphic design

Giorgio Cedolin

Images

Ikon Srl (studio)

Massimo Spada (location)

Art styling

Claudia Sani (studio)

Daniela Moioli (location)

Fonts

Forza, Vitesse

by Jonathan Hoefler

& Tobias Frere-Jones

Print

Grafiche Antiga Spa

© Fantin Srl

The photographs and drawings in this catalogue are only a representation of products and may be varied and changed without notice.

Our products are designed and built using state-of-the-art techniques, in compliance with the safety provisions specified in Italian Leg. Decree 81/08.

Las imágenes y los diseños presentes en este catálogo son solamente representaciones de los productos y podrían cambiar sin previo aviso.

Nuestros productos son diseñados y fabricados mediante técnicas de vanguardia, cumpliendo con las respectivas exigencias en materia de seguridad, según el Decreto Legislativo italiano 81/08.

Les images et les dessins figurant dans ce catalogue sont purement représentatifs des produits et peuvent faire l'objet de changements et de modifications sans préavis.

Nos produits sont conçus et fabriqués selon l'état de l'art, dans le respect des exigences de sécurité qui s'y rapportent, conformément au décret législatif italien n° 81/08.



stampato
con il sole

**PREMIUM
COLORPRINT**



UNI EN ISO 9001

See also:

[Tone on tone](#)

[Places](#)

[Finishes](#)

[Care](#)

Fantin Srl

via San Vito, 43

33080 - Bannia

di Fiume Veneto (PN)

Italia

-

t +39 0434 959 133

-

fantin@fantin.com

www.fantin.com

Spazio Fantin Milano

corso Garibaldi, 34

20121 - Milano

Italia

-

milano@fantin.com

Follow us on:

[Instagram](#)

[LinkedIn](#)

[Facebook](#)

