

Uno

Dorino Fantin, 1973

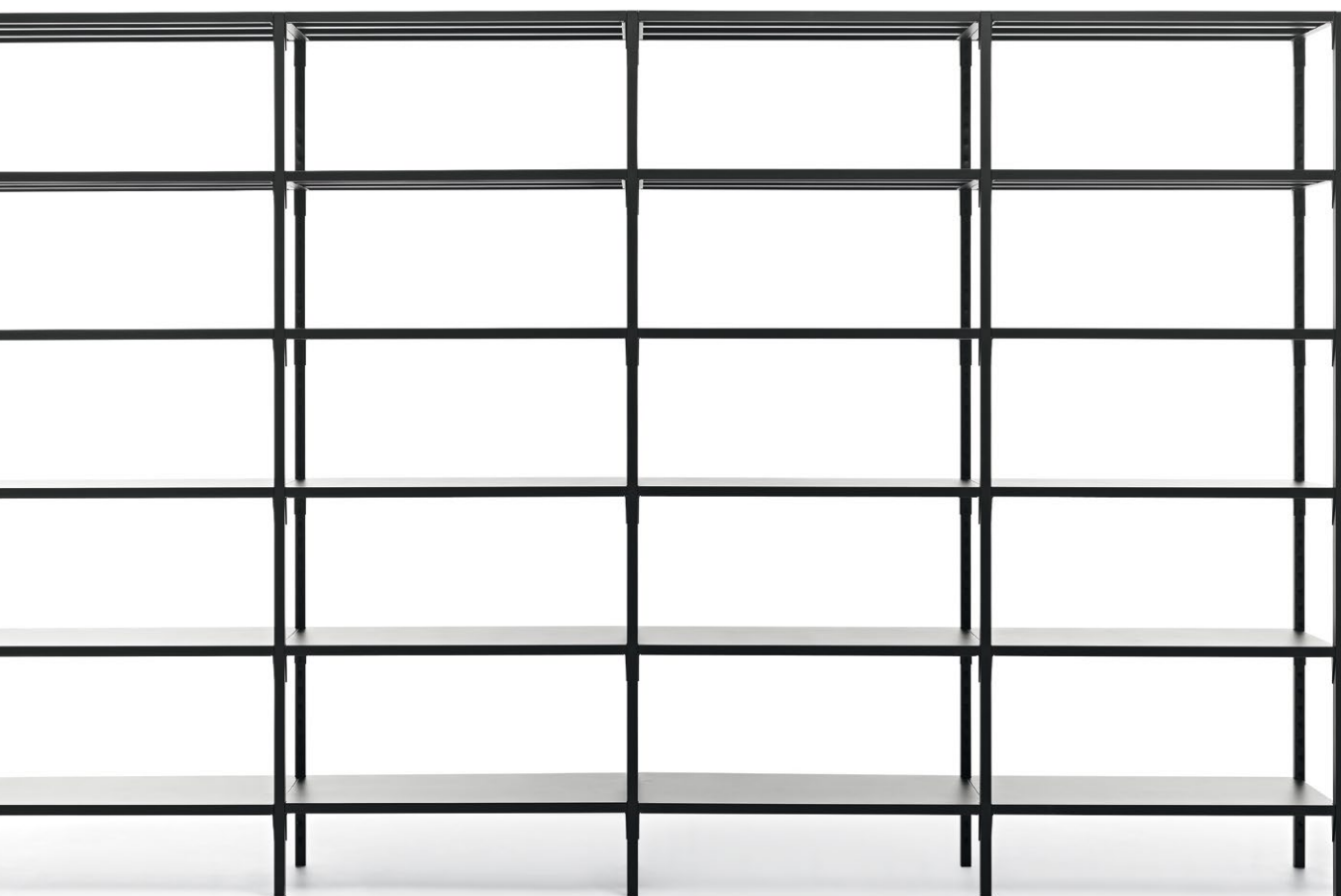

Uprights / Montantes / Montants

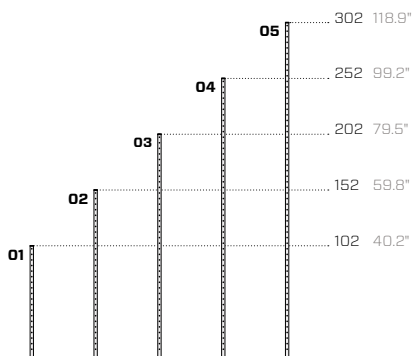

Slot pitch / Paso del orificio / Pas des trous = 5 cm / 1.9"

Shelves / Estantes / Étagères

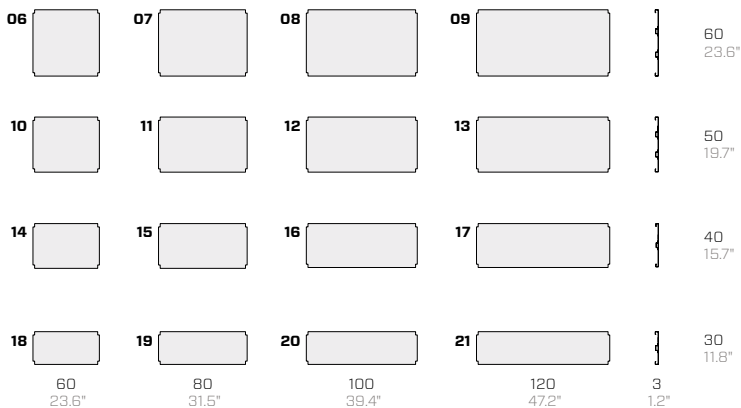

Explanatory compositions / Composiciones explicativas / Compositions explicatives

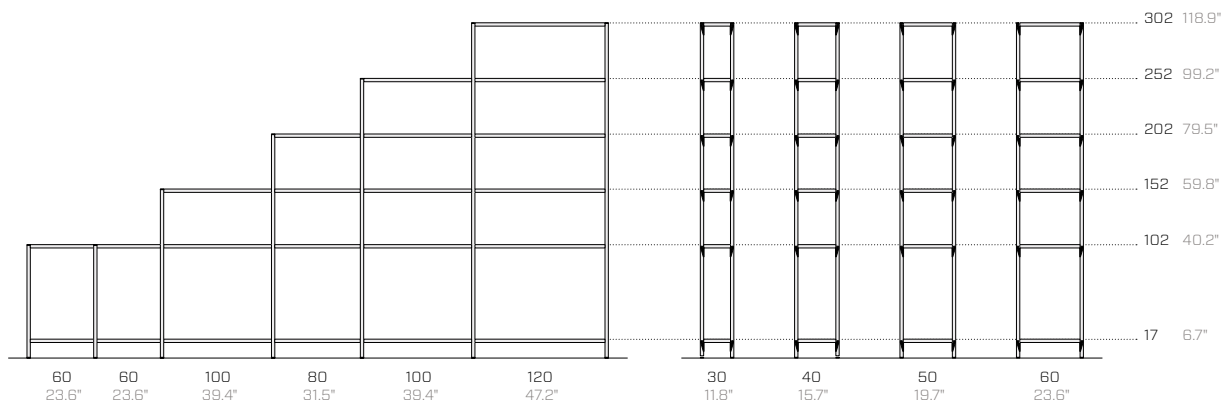

Minimum height of first shelf / Altura mínima del primer estante / Hauteur minimum de la première étagère = 17 cm / 6.7"

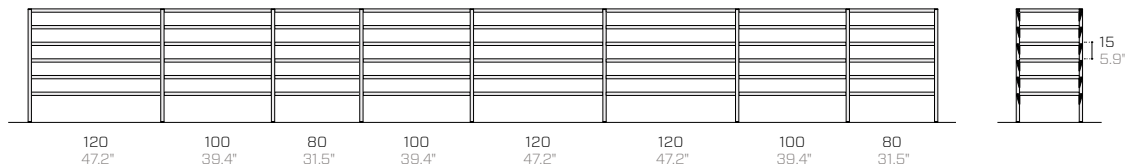

Minimum pitch between shelves / Paso mínimo entre estantes / Pas minimum entre les étagères = 15 cm / 5.9"

Always add **5 cm (1.97")** to the nominal length of compositions, to allow for the overall dimensions of click-fasteners and uprights at the ends.

Añadir siempre **5 cm (1.97")** a la longitud nominal de las composiciones para calcular también las dimensiones totales de los ganchos y montantes ubicados en los extremos.

Toujours ajouter **5 cm (1.97")** à la longueur nominale des compositions, afin de calculer également les dimensions des crochets et des montants situés aux extrémités.

Es.: 120 + 100 + 80 + 100 + 120 + 120 + 100 + 80 + 5 = 825 cm

47.2" + 39.4" + 31.5" + 39.4" + 47.2" + 47.2" + 39.4" + 31.5" + 1.97" = 324.8"

Product / Producto / Produit

Packaging / Embalaje / Emballage

No.	Code	Dimensions (w-d-h)	Weight	Max capacity	Dimensions (w-d-h)	Weight	Vol pkg
No.	Código	Dimensiones (l-a-a)	Peso	Capacidad max	Dimensiones (l-a-a)	Peso	Vol. paq.
N°	Code	Dimensions (l-p-h)	Poids	Charge maxi	Dimensions (l-p-h)	Poids	Vol. paq.
:	:	cm	kg	:	cm	kg	mc

Uprights / Montantes / Montants

01	FG100MON	3	3	102	1.1	–	–	–	1.2	0.01
02	FG150MON	3	3	152	1.7	–	–	–	1.8	0.01
03	FG200MON	3	3	202	2.3	–	–	–	2.4	0.01
04	FG250MON	3	3	252	2.9	–	–	–	3.0	0.01
05	FG300MON	3	3	302	3.5	–	–	–	3.6	0.01

Shelves / Estantes / Étagères

06	FG606RIP	60	60	3	3.5	150	61	61	13	15.6	0.05
07	FG806RIP	80	60	3	4.9	200	81	61	13	21.2	0.06
08	FG106RIP	100	60	3	6.4	200	101	61	13	27.2	0.08
09	FG126RIP	120	60	3	7.6	150	121	61	13	32.0	0.10
10	FG605RIP	60	50	3	3.3	150	61	51	13	14.8	0.04
11	FG805RIP	80	50	3	4.4	200	81	51	13	19.2	0.05
12	FG105RIP	100	50	3	5.5	200	101	51	13	23.6	0.07
13	FG125RIP	120	50	3	6.3	150	121	51	13	26.8	0.08
14	FG604RIP	60	40	3	2.2	150	61	41	13	10.4	0.03
15	FG804RIP	80	40	3	3.3	200	81	41	13	14.8	0.04
16	FG104RIP	100	40	3	4.4	150	101	41	13	19.2	0.05
17	FG124RIP	120	40	3	4.9	120	121	41	13	21.2	0.06
18	FG603RIP	60	30	3	2.3	120	61	31	13	10.8	0.02
19	FG803RIP	80	30	3	2.8	200	81	31	13	12.8	0.03
20	FG103RIP	100	30	3	3.3	150	101	31	13	14.8	0.04
21	FG123RIP	120	30	3	4.0	120	121	31	13	17.6	0.05

Fastener and half fastener / Gancho y medio gancho / Crochet et demi-crochet

22	FG001GAN	4.5	3.2	9.7	0.12	–	–	–	–	–
23	FG001GANM	4.5	3.2	9.7	0.12	–	–	–	–	–

The packaging details for the uprights will depend on the composition. The packaging details for the shelves are per pack of 4 items.

Los datos de embalaje de los montantes se establecen en función de la composición. Los datos de embalaje de los estantes están destinados a paquetes de cuatro piezas cada uno. Les données d'emballage des montants sont établies en fonction de la composition. Les données d'emballage des étagères sont pour des paquets de 4 pièces chacun.

Any composition requires stability and anti-tilting systems.

Cualquier composición requiere sistemas de estabilidad y antivuelco.

Toute composition nécessite des systèmes de stabilité et anti-basculément.



Fastener / Gancho / Crochet



Half fastener / Medio gancho / Demi-crochet

Fasteners and half-fasteners are available in the same colour as the frame or in a second Fantin colour.

Los ganchos y medios ganchos están disponibles en el mismo color que la estructura o en un segundo color Fantin.

Les crochets et les demi-crochets sont proposés dans le même coloris que le cadre ou dans une autre couleur de la palette Fantin.

Stability and anti-tip systems / Sistemas de estabilidad y antivuelco / Systèmes de stabilité et anti-basculement

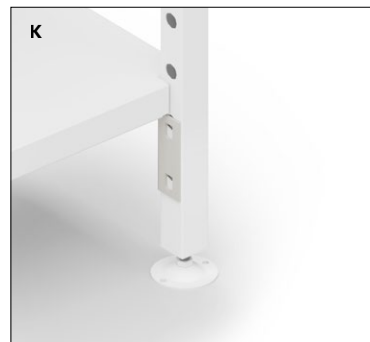
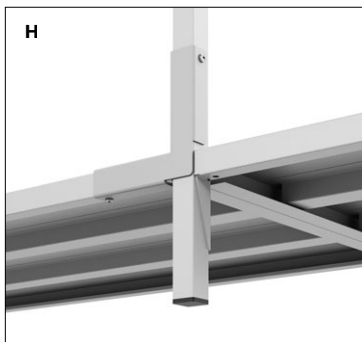
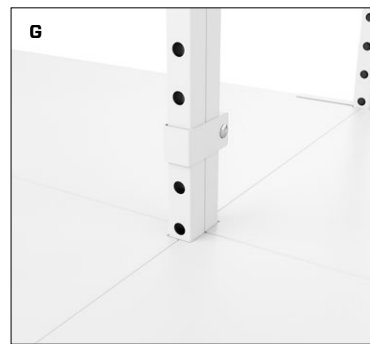
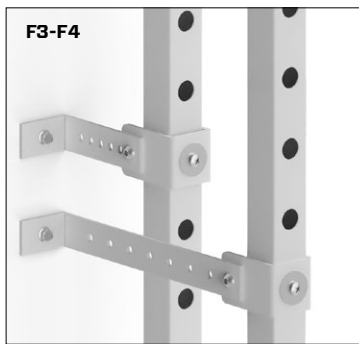
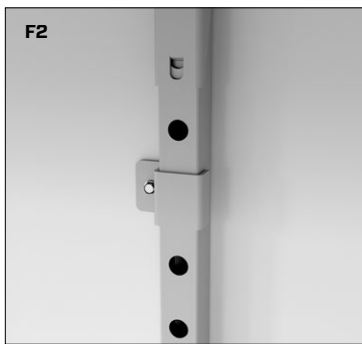
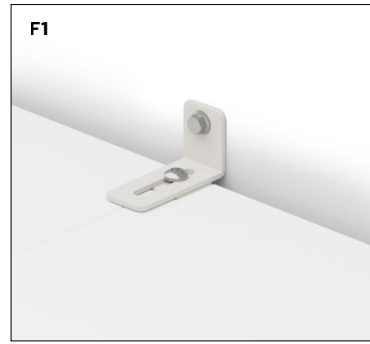
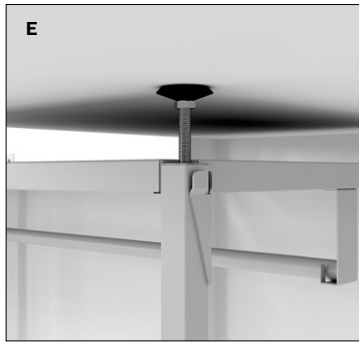
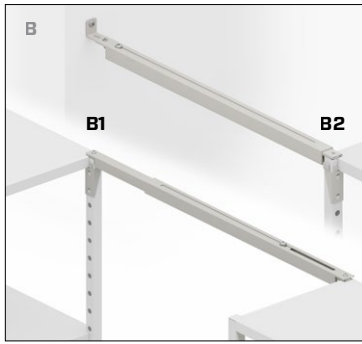
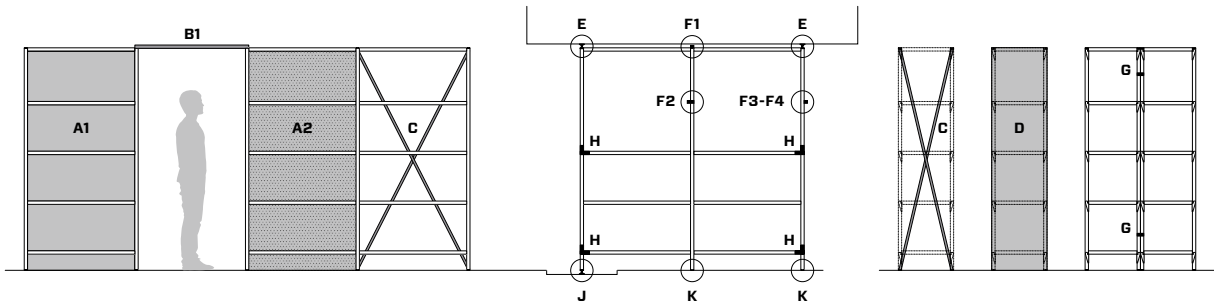

Product / Producto / Produit					Packaging / Embalaje / Emballage			
No.	Code	Dimensions (w-d-h)	Weight	Max capacity	Dimensions (w-d-h)	Weight	Vol pkg	
No.	Código	Dimensiones (l-a-a)	Peso	Capacidad max	Dimensiones (l-a-a)	Peso	Vol. paq.	
Nº	Code	Dimensions (l-p-h)	Poids	Charge maxi	Dimensions (l-p-h)	Poids	Vol. paq.	
		cm	kg		cm	kg	mc	
Full-height blind back [€/m2] / Fondo ciego de altura completa [€/mq] / Panneau arrière plein à pleine hauteur [€/mq]								
A1	FG014SCH	- - -	-	-	- - -	-	-	
Full-height perforated (Ø2 cm) back [€/m2] / Fondo perforado (Ø2 cm) de altura completa [€/mq] / Panneau arrière perforé (Ø2 cm) à pleine hauteur [€/mq]								
A2	FG014SCH-F20	- - -	-	-	- - -	-	-	
Telescopic corridor bridge 77-145 cm / Puente telescópico en pasillo 77-145 cm / Pont télescopique pour allées 77-145 cm								
B1	FG80POT	- 3.5 3.5	2.5	-	- - -	-	-	
B2	FG80PTP	- 3.5 3.5	2.5	-	- - -	-	-	
Diagonals kits / Kit de diagonales / Kit de diagonales								
C	FGDIA-102	2 0.5 100	2.3	-	- - -	-	-	
C	FGDIA-152	2 0.5 150	2.7	-	- - -	-	-	
C	FGDIA-202	2 0.5 200	3.0	-	- - -	-	-	
C	FGDIA-252	2 0.5 250	3.5	-	- - -	-	-	
C	FGDIA-302	2 0.5 300	3.9	-	- - -	-	-	
Full-height blind side kit [€/m2] / Kit lateral ciego de altura completa [€/mq] / Kit panneau latéral plein à pleine hauteur [€/qm]								
D	FG016FIA	- - -	-	-	- - -	-	-	
Adjustable ceiling fastening / Fijación ajustable en techo / Fixation de plafond ajustable								
E	FG009STA	5 5 8	0.1	-	- - -	-	-	
Wall brackets / Bidas de pared / Supports muraux								
F1	FG172STA	6.0 4.0 4.0	0.1	-	- - -	-	-	
F2	FG171STA	6.0 3.0 4.0	0.1	-	- - -	-	-	
F3	FG010STA	2.5 0.3 8.6	0.1	-	- - -	-	-	
F4	FG011STA	2.5 0.3 20.0	0.2	-	- - -	-	-	
U-shaped junction bracket / Brida de unión en U / Support de raccordement en U								
G	FG007STA	8 3.5 4	0.1	-	- - -	-	-	
L-shaped stability bracket / Brida de estabilidad en L / Support de stabilité en L								
H	FG283L	15 2.5 15	0.3	-	- - -	-	-	
Adjustable foot / Pata ajustable / Pied réglable								
J	FG005STA	3 3 8.5	0.2	-	- - -	-	-	
Adj. bracket for floor fixing (frame-matching finish) / Soporte aj. para fijación al suelo (color del marco) / Support régl. pour fixation au sol (assorti au cadre)								
K	FG013STA	5.7 5.7 2	0.1	-	- - -	-	-	

Any composition requires stability and anti-tilting systems, found on these pages and the next two pages (L, M, N).

Cualquier composición requiere sistemas de estabilidad y antivuelco, presentes en estas páginas y en las dos páginas siguientes (L, M, N).

Toute composition nécessite des systèmes de stabilité et anti-basculement, présents sur ces pages et les deux pages suivantes (L, M, N).

Doors, sides and filler panels / Puertas, laterales y rellenos / Portes, panneaux latéraux et panneau de finition

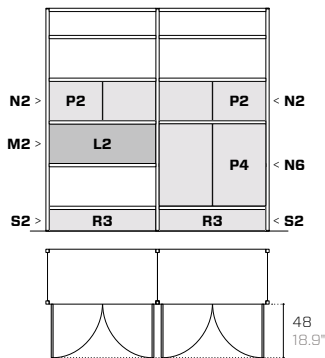

L, M, N are also stability systems
 L, M, N también son sistemas de estabilidad
 L, M, N sont également des systèmes de stabilité

Product / Producto / Produit

Packaging / Embalaje / Emballage

No.	Code	Dimensions (w-d-h)	Weight	Max capacity	Dimensions (w-d-h)	Weight	Vol pkg
No.	Código	Dimensiones (l-a-a)	Peso	Capacidad max	Dimensiones (l-a-a)	Peso	Vol. paq.
Nº	Code	Dimensions (l-p-h)	Poids	Charge maxi	Dimensions (l-p-h)	Poids	Vol. paq.
:	:	cm	kg	:	cm	kg	mc

Back panels for compartment / Fondos para compartimiento / Panneaux arrière pour compartiment

L1	F0339	77 1 37	1.8	-	-	-	-
L2	F0340	97 1 37	2.3	-	-	-	-
L3	F0402	77 1 77	3.2	-	-	-	-
L4	F0403	97 1 77	4.0	-	-	-	-

Side panels for compartment / Laterales para compartimiento / Panneaux latéraux pour compartiment

M1	F0368	3 24 37	1.0	-	-	-	-
M2	F0361	3 34 37	1.5	-	-	-	-
M3	F0369	3 44 37	2.0	-	-	-	-
M4	F0370	3 54 37	2.5	-	-	-	-

Side panels for door kit / Laterales para kit de puertas / Panneaux latéraux pour kit de portes

N1	F0364	4.5 24 37	1.0	-	-	-	-
N2	F0341	4.5 34 37	1.5	-	-	-	-
N3	F0366	4.5 44 37	2.0	-	-	-	-
N4	F0367	4.5 54 37	2.5	-	-	-	-
N5	F0406	4.5 24 77	2.0	-	-	-	-
N6	F0407	4.5 34 77	3.0	-	-	-	-
N7	F0408	4.5 44 77	4.0	-	-	-	-
N8	F0409	4.5 54 77	5.0	-	-	-	-

2-doors kits / Kit de dos puertas / Kit deux portes

P1	F0342	77 2 37	7.3	-	-	-	-
P2	F0343	97 2 37	8.0	-	-	-	-
P3	F0404	77 2 77	15.0	-	-	-	-
P4	F0405	97 2 77	17.0	-	-	-	-

End pieces / Pieza final / Pièces d'extrémité

Q1	FG30ELR	1.5 24 3	0.2	-	-	-	-
Q2	FG40ELR	1.5 34 3	0.2	-	-	-	-
Q3	FG50ELR	1.5 44 3	0.3	-	-	-	-
Q4	FG60ELR	1.5 54 3	0.3	-	-	-	-

Front base sections / Zócalos delanteros / Plinthes de façade

R1	FGZ60	57 2.5 14	0.8	-	-	-	-
R2	FGZ80	77 2.5 14	1.0	-	-	-	-
R3	FGZ100	97 2.5 14	1.2	-	-	-	-
R4	FGZ120	117 2.5 14	1.4	-	-	-	-

Side base sections / Zócalos laterales / Plinthes latérales

S1	FGZ30L	2.5 24 14	0.4	-	-	-	-
S2	FGZ40L	2.5 34 14	0.5	-	-	-	-
S3	FGZ50L	2.5 44 14	0.6	-	-	-	-
S4	FGZ60L	2.5 54 14	0.7	-	-	-	-

All accessories are available in the same colour as the frame or in a second Fantin colour.

Todos los accesorios están disponibles en el mismo color que la estructura o en un segundo color Fantin.

Tous les accessoires sont proposés dans le même coloris que le cadre ou dans une autre couleur de la palette Fantin.

Accessories / Accesorios / Accessoires

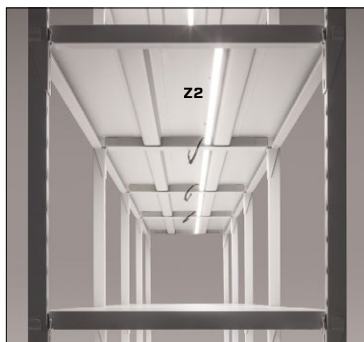
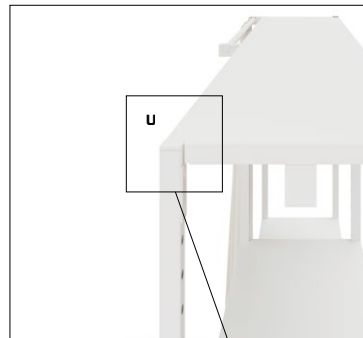
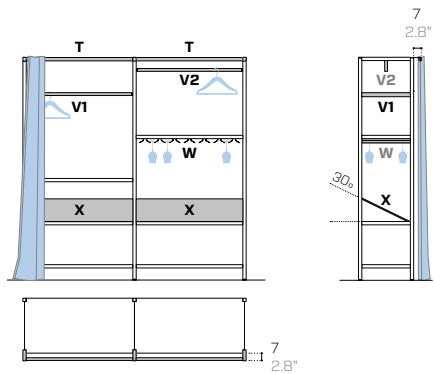

LED bars with magnetic attachment (upon request, LED power cable covers are available for mounting on the uprights, as well as power supply brackets to be fixed under the lower shelves).

Barras LED con fijación magnética (bajo pedido, se suministran cubiertas para cables de alimentación LED, para montar en los montantes, y soportes para fuentes de alimentación, para fijar bajo los estantes inferiores).

Barres LED avec fixation magnétique (sur demande, des cache-câbles pour l'alimentation LED sont disponibles pour montage sur les montants, ainsi que des supports pour alimentations à fixer sous les étagères inférieures).

Product / Producto / Produit					Packaging / Embalaje / Emballage			
No.	Code	Dimensions (w-d-h)	Weight	Max capacity	Dimensions (w-d-h)	Weight	Vol pkg	
No.	Código	Dimensiones (l-a-a)	Peso	Capacidad max	Dimensiones (l-a-a)	Peso	Vol. paq.	
Nº	Code	Dimensions (l-p-h)	Poids	Charge maxi	Dimensions (l-p-h)	Poids	Vol. paq.	
		cm	kg		cm	kg	mc	
Curtain Rod 60-120 cm / Barra para cortina 60-120 cm / Tringle à rideaux 60-120 cm								
T	FG015TEND	- 3 4	-	-	- - -	-	-	
Colour-matching metal cap / Tapa de metal a juego / Capuchon en métal assorti								
U	FG008STA	3 3 0.5	0.1	-	- - -	-	-	
Clothes rail hookable to the uprights / Perchero con opción de enganche a los montantes / Portemanteau pouvant être fixé aux montants								
V1	FG000AP	- - -	0.8	-	- - -	-	-	
Clothes rail kit attached to the shelf / Perchero fijo en estante / Portemanteau fixe sur étagère								
V2	F292G	- 2.5 2.5	-	-	- - -	-	-	
Glass holder (minimum 2 items) / Portavasos (mínimo 2 piezas) / Râtelier à verres (minimum 2 pièces)								
W	FG021B	10 - 3.5	-	-	- - -	-	-	
30° sloping shelves, resting type, 60-120 cm / Estantes inclinados 30°, de apoyo, 60-120 cm / Étagères inclinées à 30°, en appui, 60-120 cm								
X	FG000RINY	- - -	-	-	- - -	-	-	
Bookends / Sujetalibros / Serre-livres								
Y1	F281	18.5 25 19	0.7	-	- - -	-	-	
Y2	FG000LIB	12.5 - 17	1.4	-	- - -	-	-	
LED bars 3000K (10W per meter) / Barras LED 3000K (10W por metro) / Barres LED 3000K (10W par mètre)								
Z1	FG60L3	55 2 3	0.1	-	58 5 6	0.1	0.1	
Z2	FG80L3	75 2 3	0.1	-	78 5 6	0.2	0.1	
Z3	FG100L3	95 2 3	0.2	-	98 5 6	0.3	0.1	
Z4	FG120L3	115 2 3	0.2	-	118 5 6	0.3	0.1	
24V-20W power supply kit / Kit con fuente de alimentación 24V-20W / Kit avec alimentation 24V-20W								
-	FGK1LPS	60 - 3	2.5	-	63 - 6	2.6	0.1	
24V-50W power supply kit / Kit con fuente de alimentación 24V-50W / Kit avec alimentation 24V-50W								
-	FGK2LPS	60 - 3	2.6	-	63 - 6	2.8	0.1	
24V-75W power supply kit / Kit con fuente de alimentación 24V-75W / Kit avec alimentation 24V-75W								
-	FGK3LPS	60 - 3	2.8	-	63 - 6	3	0.1	
LED dimmer remote control / Mando a distancia regulador LED / Télécommande variateur LED								
-	FGK6D	9 9 2	0.1	-	10 10 5	0.1	0.1	

All accessories are available in the same colour as the frame or in a second Fantin colour.

Todos los accesorios están disponibles en el mismo color que la estructura o en un segundo color Fantin.

Tous les accessoires sont proposés dans le même coloris que le cadre ou dans une autre couleur de la palette Fantin.

Wardrobe 1 / Armario 1 / Dressing 1a

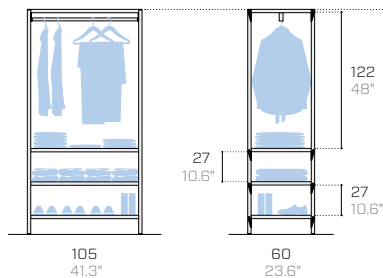

Wardrobe 2 / Armario 2 / Dressing 2



202 79.5"

Bookcase / Biblioteca / Bibliothèque

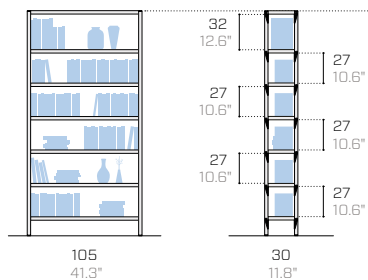

Office / Oficina / Bureau

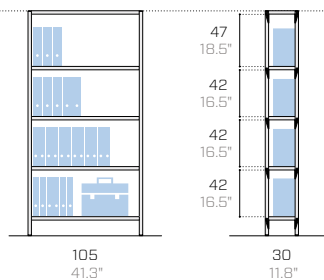

202 79.5"

Wine store / Enoteca / Cave à vin

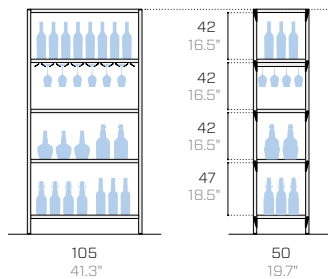

Gym / Gimnasio / Salle de gym

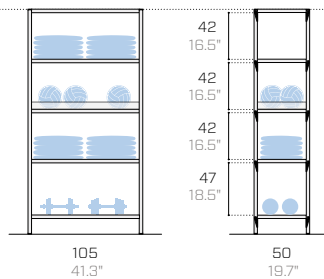

202 79.5"

Garage / Garaje / Garage

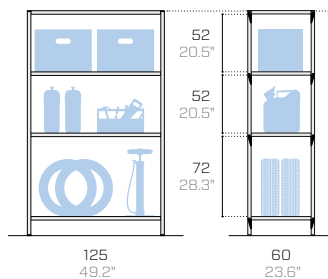

Laundry room / Lavandería / Buanderie

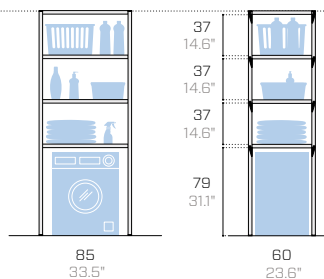

202 79.5"

Examples of compositions / Ejemplos de composiciones / Exemples de compositions

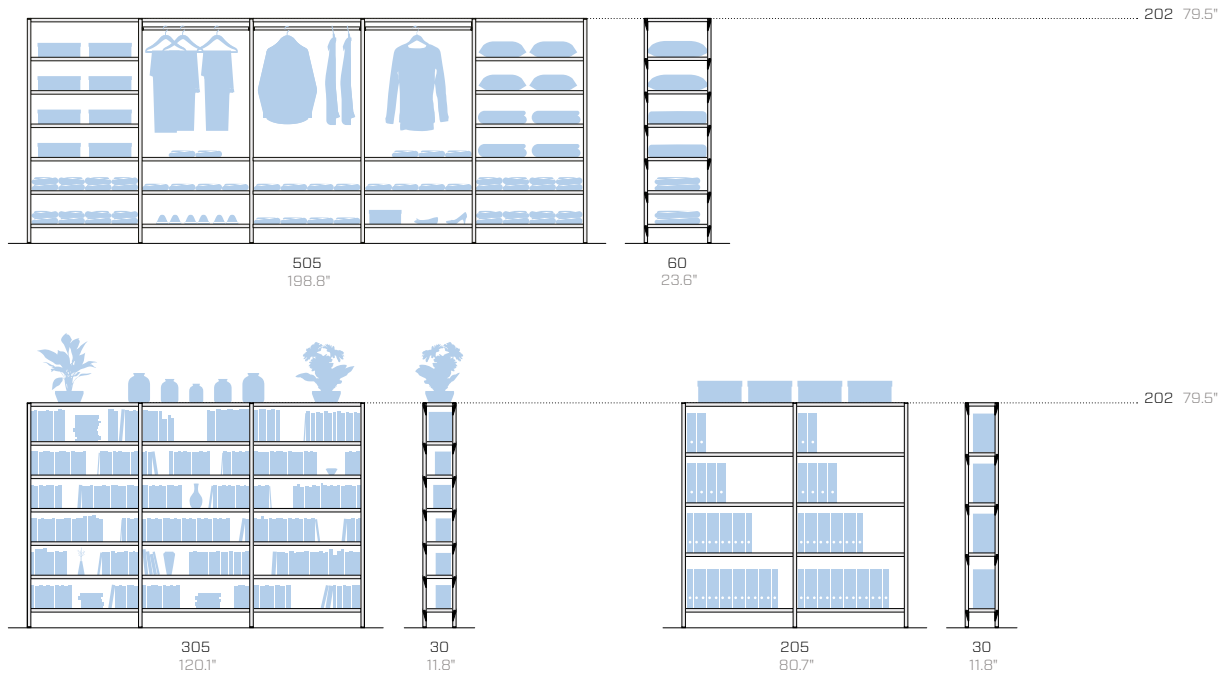

Maximum capacity per bay / Capacidad máxima por compartimiento / Charge maximale par élément

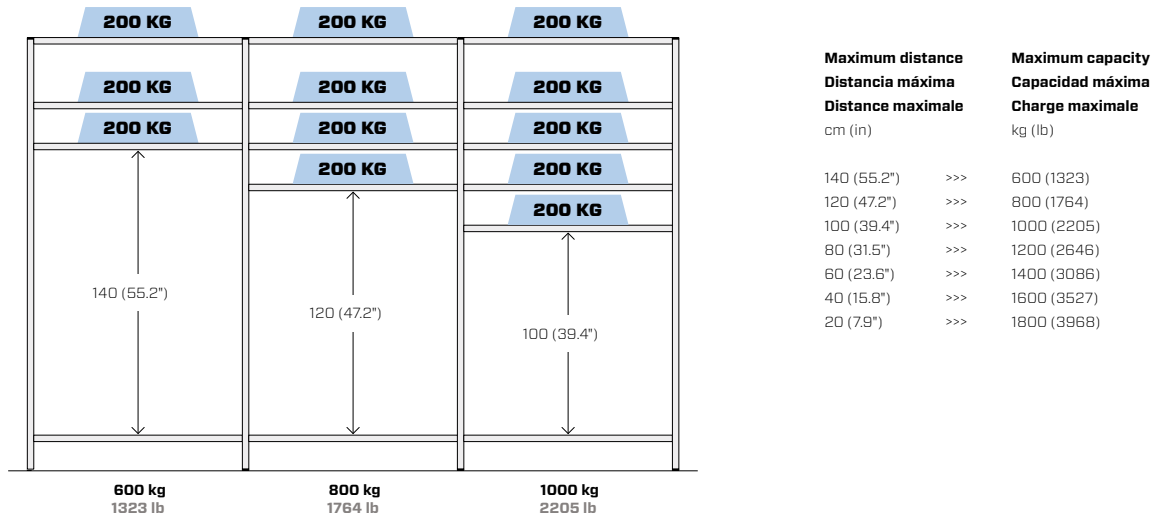

Any composition requires stability and anti-tilting systems.
 Cualquier composición requiere sistemas de estabilidad y antivuelco.
 Toute composition nécessite des systèmes de stabilité et anti-basculement.

Metal essentials

	<p>01.18 Black (RAL 9005) Negro / Noir --- EM ▲</p>		<p>08.20 Rose quartz Rosa cuarzo / Quartz rose --- EM ▲■</p>		<p>15.19 Forest green (RAL 6007) Verde bosque / Verte forêt --- EM ▲●</p>
	<p>02.18 Anthracite (RAL 7021) Antracita / Anthracite --- EM ▲●■</p>		<p>09.24 Terracotta (RAL 8004) Terracota / Terre cuite --- EM ▲●■</p>		<p>16.24 Cement (RAL 7033) Cemento / Ciment --- EM ▲●■</p>
	<p>03.18 Fantin grey Fantin gris / Gris Fantin --- EM ▲●■</p>		<p>10.21 Flame red (RAL 3000) Rojo Fuego / Rouge feu --- EM ▲</p>		<p>17.24 Slate (RAL 7031) Pizarra / Ardoise --- EM ▲●■</p>
	<p>04.18 Light grey (RAL 7035) Gris claro / Gris clair --- EM ▲●■</p>		<p>11.21 Melon yellow (RAL 1028) Amarillo melón / Jaune melon --- EM ▲●</p>		<p>18.21 Dusty blue (RAL 5014) Azul polvoriento / Bleu poussiéreux --- EM ▲■</p>
	<p>05.19 Cloud grey Gris nube / Gris nuage --- EM ▲■</p>		<p>12.19 Zinc yellow (RAL 1018) Amarillo zinc / Jaune de zinc --- EM ▲■</p>		<p>19.18 Gentian blue (RAL 5010) Azul genciana / Bleu gentiane --- EM ▲●</p>
	<p>06.18 White (RAL 9016) Blanco / Blanc --- EM ▲■</p>		<p>13.21 Pastel green (RAL 6019) Verde pastel / Vert pastel --- EM ▲●■</p>		<p>20.19 Steel blue (RAL 5011) Azul acero / Bleu acier --- EM ▲</p>
	<p>07.21 Milk white (RAL 9001) Blanco leche / Blanc de lait --- EM ▲●■</p>		<p>14.18 Sage green (RAL 6021) Verde salvia / Vert sauge --- EM ▲●■</p>		<p>21.21 Coffee brown (RAL 8019) Marrón café / Marron café --- EM ▲■</p>

Metal design

Metallic



61.24
Pale gold
Oro claro / Or clair

EM ▲ ■



62.24
Copper
Cobre / Cuivre

EM ▲ ● ■



47.21
Platinum
Platino / Platine

EM ▲



43.21
Bronze
Bronce / Bronze

EM ▲



63.24
Graphite
Grafito / Graphite

EM ▲ ●



64.24
Silver green
Verde plateado / Vert argenté

EM ▲ ●



65.24
Silver blue
Azul plateado / Bleu argenté

EM ▲ ●

Earth



51.18
Sand
Arena / Sable

EM ▲ ●



57.21
Clay
Creta / Crète

EM ▲ ●



52.18
Moss
Musgo / Mousse

EM ▲ ●



66.24
Lichen
Liquen / Lichen

EM ▲ ■



67.24
Pink clay
Arcilla rosa / Argile rose

EM ▲ ● ■

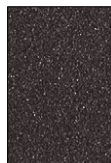

68.24
Sodalite
Sodalita / Sodalite

EM ▲



56.21
Ocean
Oceano / Océan

EM ▲

Surfaces / Superficies / Surfaces

EM Embossed / Gofrado / Gaufré

Use / Usos / Utilisations

- ▲ Tops / Encimeras / Plans
- Outdoor / Exteriores / Extérieur
- Food / Alimentario / Alimentaire

Technical information

Metal Non-toxic powder coating for interior use, with no heavy metals. Cured in an oven at 190 °C, following degreasing and phosphating. Guaranteed minimum thickness of 50 microns. Minimum resistance to salt spray of 200 hours (in accordance with the ASTM B117 standard). Some finishes are suitable for direct contact with food as required by Italian Law Decree D.M. 21/03/73 and subsequent updates. Requests for other RAL finishes can be considered. On some finishes, any partial discolouration following rubbing and/or abrasion has absolutely no effect on the technical, appearance/colour and chemical/physical characteristics of the product. This phenomenon tends to diminish over the useful life of the product and does not in any case present a health hazard to users.

Información técnica

Metal Recubrimiento en polvo atóxico para interiores, sin metales pesados, con paso en horno a 190 °C, previo tratamiento de desengrase y fosfatación. Espesor mínimo garantizado 50 micrones, resistencia mínima en niebla salina igual a 200 horas (norma ASTM B117). Algunos acabados son aptos para el contacto directo con alimentos, según lo previsto por el decreto italiano D.M. 21/03/73 y posteriores actualizaciones. Se pueden evaluar otros acabados RAL bajo pedido. En algunos acabados, una decoloración parcial debida al roce y/o a la abrasión no afecta en absoluto a las características técnicas, de aspecto/color y químicas/físicas del producto. Este fenómeno tiende a disminuir a lo largo de la vida útil del producto y no representa en ningún caso un peligro para la salud de los usuarios.

Informations techniques

Métal Revêtement en poudre non toxique pour l'intérieur sans métaux lourds, avec passage au four à 190 °C, après traitement de dégraissage et de phosphatation. Épaisseur minimale garantie de 50 microns. Résistance minimale au brouillard salin de 200 heures (norme ASTM B117). Certaines finitions sont adaptées au contact direct avec les aliments, comme l'exige l'arrêté ministériel italien du 21/03/73 et ses mises à jour ultérieures. Autres finitions RAL possibles sur demande. Sur certaines finitions, une éventuelle décoloration partielle due au frottement et/ou à l'abrasion n'a absolument aucune incidence sur les caractéristiques techniques, d'aspect/couleur et chimiques/physiques du produit. Ce phénomène tend à s'atténuer au cours de la vie utile du produit et ne présente en aucun cas un danger pour la santé des utilisateurs.

Metal frame which stands out for its speedy assembly and its stability and sturdiness. Affording potentially infinite versatility.

Uprights in 30 x 30 mm (1.18" x 1.18") tubular metal measuring 1.2 mm (0.05") in thickness, fitted with plastic caps at the ends. Along the entire length, one side features slots with a pitch of 50 mm (1.97") for the variable positioning of the click fasteners and hence of the shelves. The use of tubular metal, which provides higher performance levels than the more commonly used open section bars, ensures minimal torsional and flexural effects.

Click fasteners made of pressed sheet metal, 2.5 mm (0.10") thick. These fasteners are anchored to the uprights using two purpose-designed side fins which fit into the slots in the uprights. The shelves then click onto the upper fins of the actual click-fasteners. Every click fastener is designed to support 2 consecutive shelves simultaneously, enveloping and concurrently reinforcing the upright to which it is anchored. Fasteners and half fasteners are available to match the frame or in a second Fantin colour.

Shelves in 0.7 mm (0.03") thick sheet metal folded three times along the two front sides to prevent accidents; omega-shaped reinforcements are envisaged on the underside to increase their load capacity (UNI 8601/1984 test: level 5 out of 5). The four corners of the shelves are further reinforced with a 3 mm (0.12") thick sheet metal support that is designed to house the upright completely; this ensures perfect continuity between two consecutive shelves, without any gaps.

Push-pull doors inset in the frame, made of bent sheet metal. Door thickness: 20 mm (0.79"). Soft-close dampening hinges. 95° door opening.

This product is delivered flat-packed.

Any composition requires stability and anti-tilting system.

Estructura metálica caracterizada por un montaje rápido, estabilidad y robustez. Versatilidad potencialmente infinita.

Montantes en tubo de 30 x 30 mm (1.18" x 1.18") de espesor 1.2 mm (0.05"), con tapones de plástico en los extremos. En toda su longitud, un lado tiene orificios, con un paso de 50 mm (1.97"), que permiten un posicionamiento variable de los ganchos y, por tanto, de los estantes. El uso del tubo, de más calidad con respecto a aquellos con perfiles abiertos que se usan normalmente, garantiza efectos mínimos de torsión y flexión.

Ganchos realizados en chapa apezonada de 2.5 mm (0.10") de espesor. El anclaje al montante es posible mediante dos aletas laterales que se encajan en los orificios de los montantes. Luego, los estantes se fijan encajándolos en las aletas superiores de los mismos ganchos. Cada gancho puede soportar simultáneamente 2 estantes consecutivos, abrazando y reforzando al mismo tiempo el montante al que está anclado. Los ganchos y medios ganchos están disponibles en el mismo color que la estructura o en un segundo color Fantin.

Estantes en chapa de 0.7 mm (0.03") de espesor con plegado triple en los dos lados frontales, con función de protección contra accidentes. En la parte inferior cuentan con refuerzos omega que aumentan significativamente la capacidad de carga (prueba UNI 8601/1984: nivel 5 sobre 5). Las cuatro esquinas de los estantes se refuerzan aún más con un soporte de chapa de 3 mm (0.12") de espesor que permite el alojamiento completo del montante, con el fin de obtener una continuidad perfecta entre dos estantes consecutivos, sin espacios.

Puertas push-pull insertadas en el marco, en chapa plegada. Espesor de las puertas: 20 mm (0.79"). Bisagras amortiguadoras de cierre suave. Apertura de las puertas de 95°.

El producto se suministra desmontado.

Cualquier composición requiere sistemas de estabilidad y antivuelco.

Structure métallique qui se distingue par son montage rapide, sa stabilité et sa robustesse. Une polyvalence potentiellement infinie.

Montants tubulaires de 30 x 30 mm (1.18" x 1.18") de 1,2 mm (0.05") d'épaisseur, munis de capuchons en plastique aux extrémités. Sur toute la longueur, un côté présente des trous au pas de 50 mm (1.97") qui permettent un positionnement variable des crochets et donc des étagères. L'utilisation du tube, plus performant que les profilés ouverts couramment utilisés, garantit des effets de torsion et de flexion moindres.

Crochets en tôle emboutie de 2.5 mm (0.10") d'épaisseur. L'ancrage au montant est assuré par deux ergots latéraux qui s'emboîtent dans les trous des montants. Les étagères sont ensuite emboîtées sur les ergots supérieurs des crochets en question. Chaque crochet peut supporter simultanément 2 étagères consécutives, tout en épousant et en renforçant le montant auquel il est ancré. Les crochets et les demi-crochets sont proposés dans le même coloris que le cadre ou dans une autre couleur de la palette Fantin.

Étagères en tôle de 0.7 mm (0.03") d'épaisseur avec triple pliage sur les deux faces avant ayant fonction de sécurité ; des omégas de renfort sur la face inférieure augmentent considérablement la capacité de charge (test UNI 8601/1984 : niveau 5 sur 5). Les quatre coins des étagères sont en outre renforcés par un support en tôle de 3 mm (0.12") d'épaisseur qui permet de loger entièrement le montant, afin d'obtenir une continuité parfaite entre deux étagères consécutives, sans aucun vide.

Portes push-pull encastrées à fleur du cadre, en tôle pliée. Épaisseur des portes : 20 mm (0.79"). Charnières amorties. Ouverture des portes à 95°.

Le produit est livré non monté.

Toute composition nécessite des systèmes de stabilité et anti-basculement.



Assembly video
Vídeo de montaje
Vidéo de montage



Configurator
Configurador
Configurateur

Disclaimer / Descargo de responsabilidad / Exclusion de responsabilité

Fantin Srl reserves the right to change the dimensions and features of the products contained in this technical data sheet at any time and without prior notice. The finishes illustrated are purely indicative as the accuracy tolerances of printing processes should be taken into account.

Fantin Srl se reserva el derecho de modificar en cualquier momento y sin previo aviso las dimensiones y ejecución de los productos presentes en esta ficha técnica. Los acabados mostrados son indicativos, ya que están sujetos a las tolerancias de los procesos de impresión.

Fantin Srl se réserve le droit de modifier à n'importe quel moment et sans préavis les dimensions et la fabrication des produits contenus dans cette fiche technique. Les finitions indiquées sont données à titre indicatif puisqu'elles sont sujettes aux tolérances des procédés d'impression.

Fantin Srl

via San Vito, 43
33080 - Bannia
di Fiume Veneto (PN)
Italia

t +39 0434 959 133
f +39 0434 560 037
fantin@fantin.com
www.fantin.com

